



# Inclusive & Di-Jet Mass Cross Sections

at  $\sqrt{s} = 1.96 \text{ TeV}$

Bob Hrosky

University of Virginia

On Behalf of the DØ Collaboration

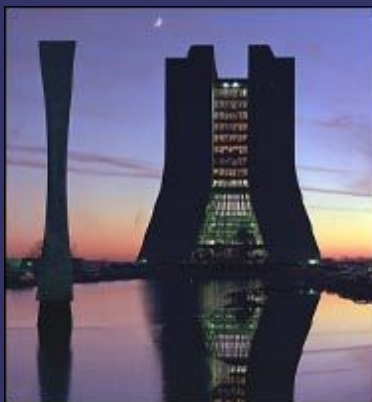

## QCD at highest $Q^2$ at the Tevatron

- Precision tests of pQCD
- Phenomenological models for “soft” aspects of QCD
- Tuning of Monte Carlo generators
- Probing for new physics
- Understanding backgrounds to many processes of interest

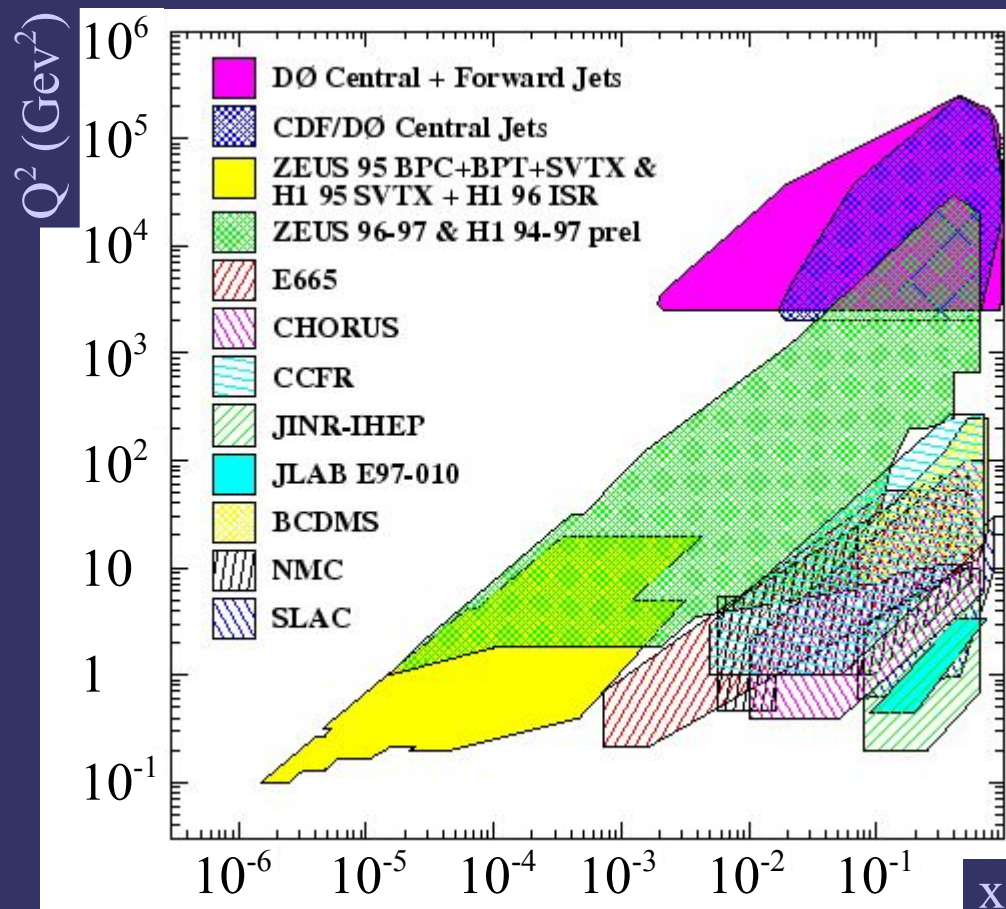



# The Fermilab Tevatron Collider

∫ Luminosity

Run I (1992-95)  $\sim 0.1 \text{ fb}^{-1}$   
 $\sqrt{s} = 1.8 \text{ TeV}$

Run IIa (2001~2005)  $\sim 1 \text{ fb}^{-1}$

Run IIb (2006-2009)  $\sim 4-8 \text{ fb}^{-1}$   
 $\sqrt{s} = 1.96 \text{ TeV}$

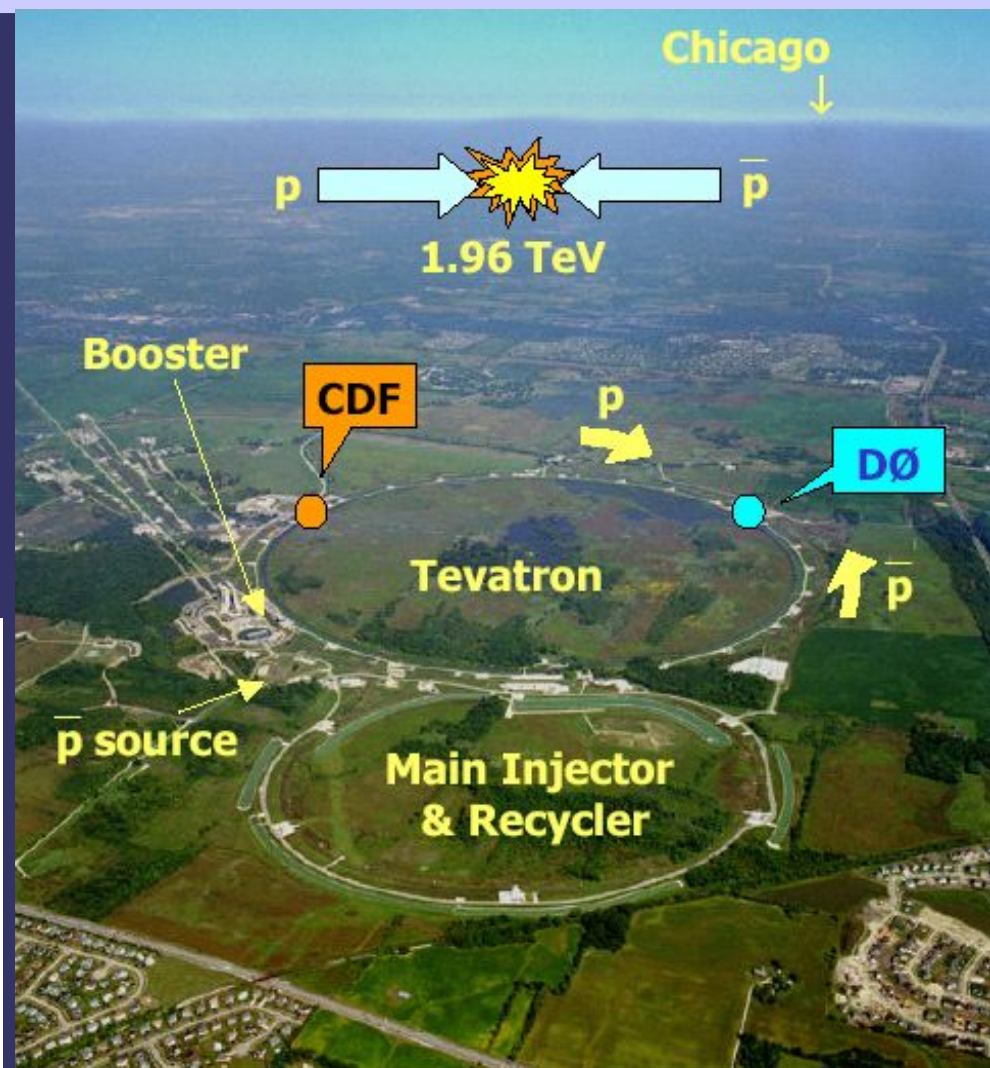
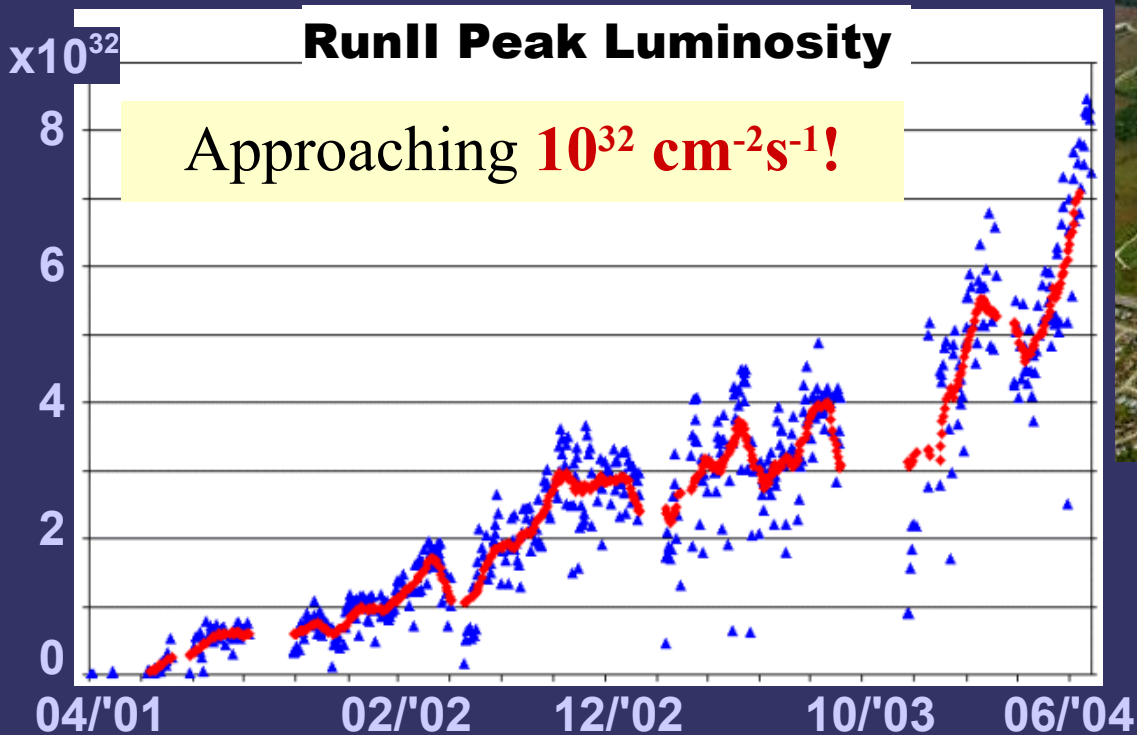

Highest-energy collider until LHC



# DØ Data Taking Performance

## Run II Integrated Luminosity 04/02 - 08/04

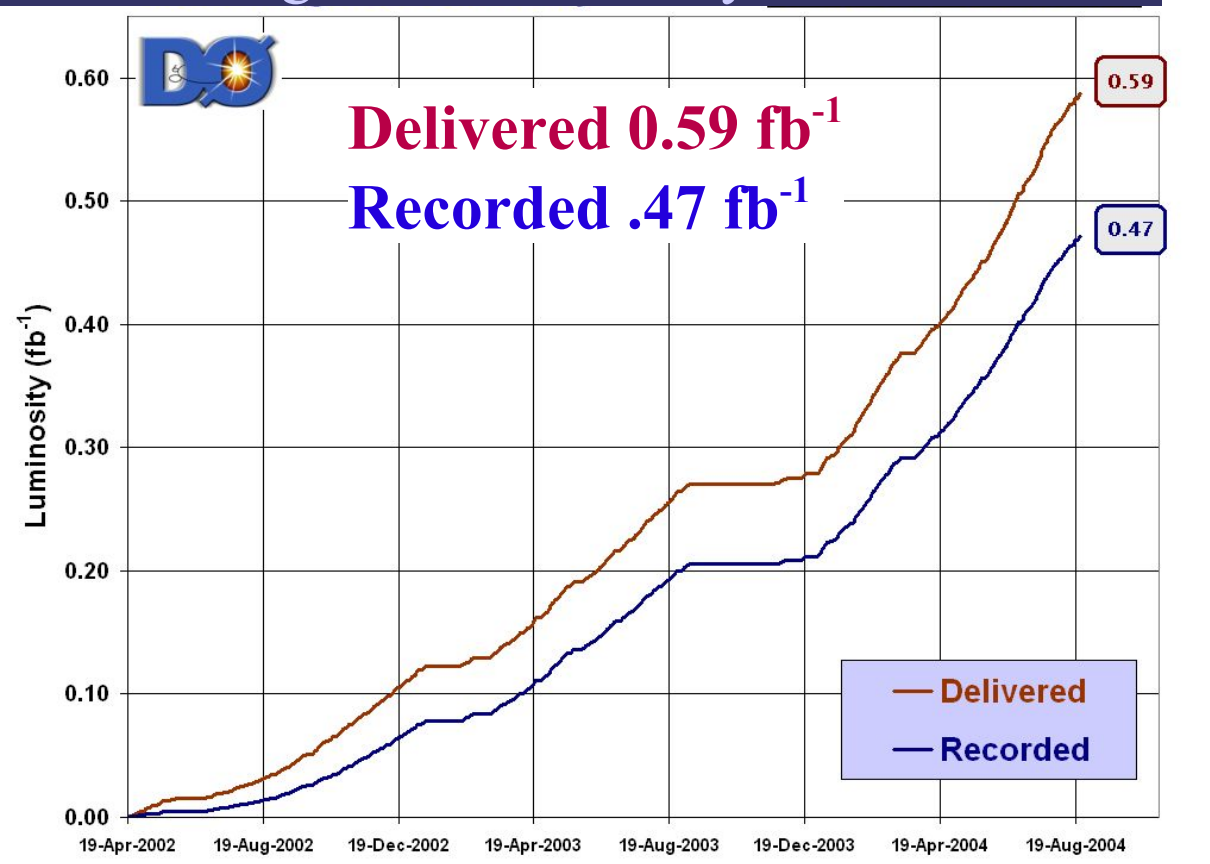

## Data taking Efficiency 04/02-6/04

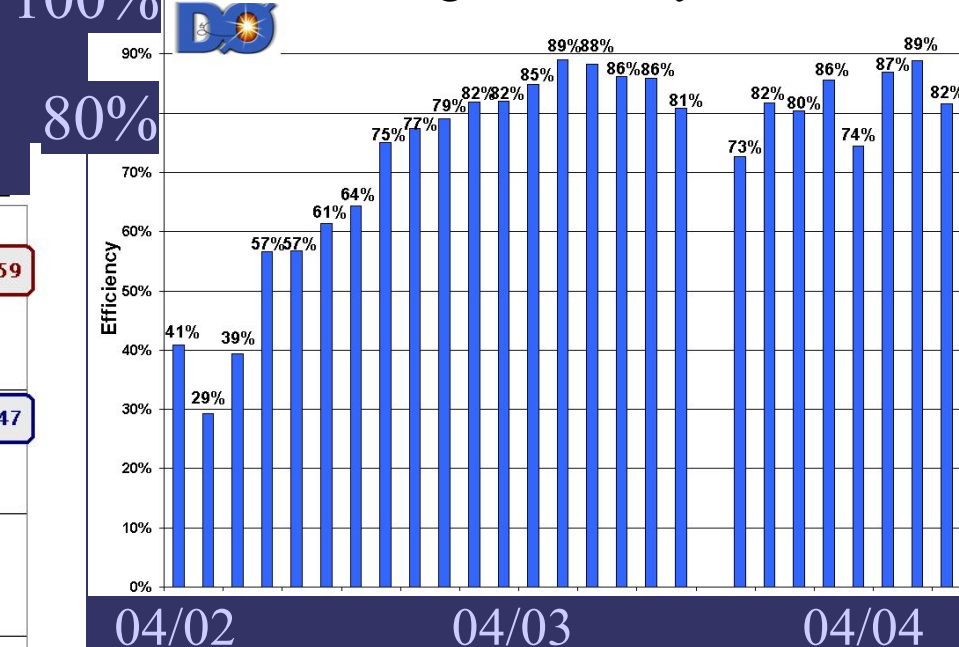

Almost 500 pb<sup>-1</sup> now recorded  
Efficiency regularly above 85%.

Results presented today are from first 143 pb<sup>-1</sup>



# The DØ Detector

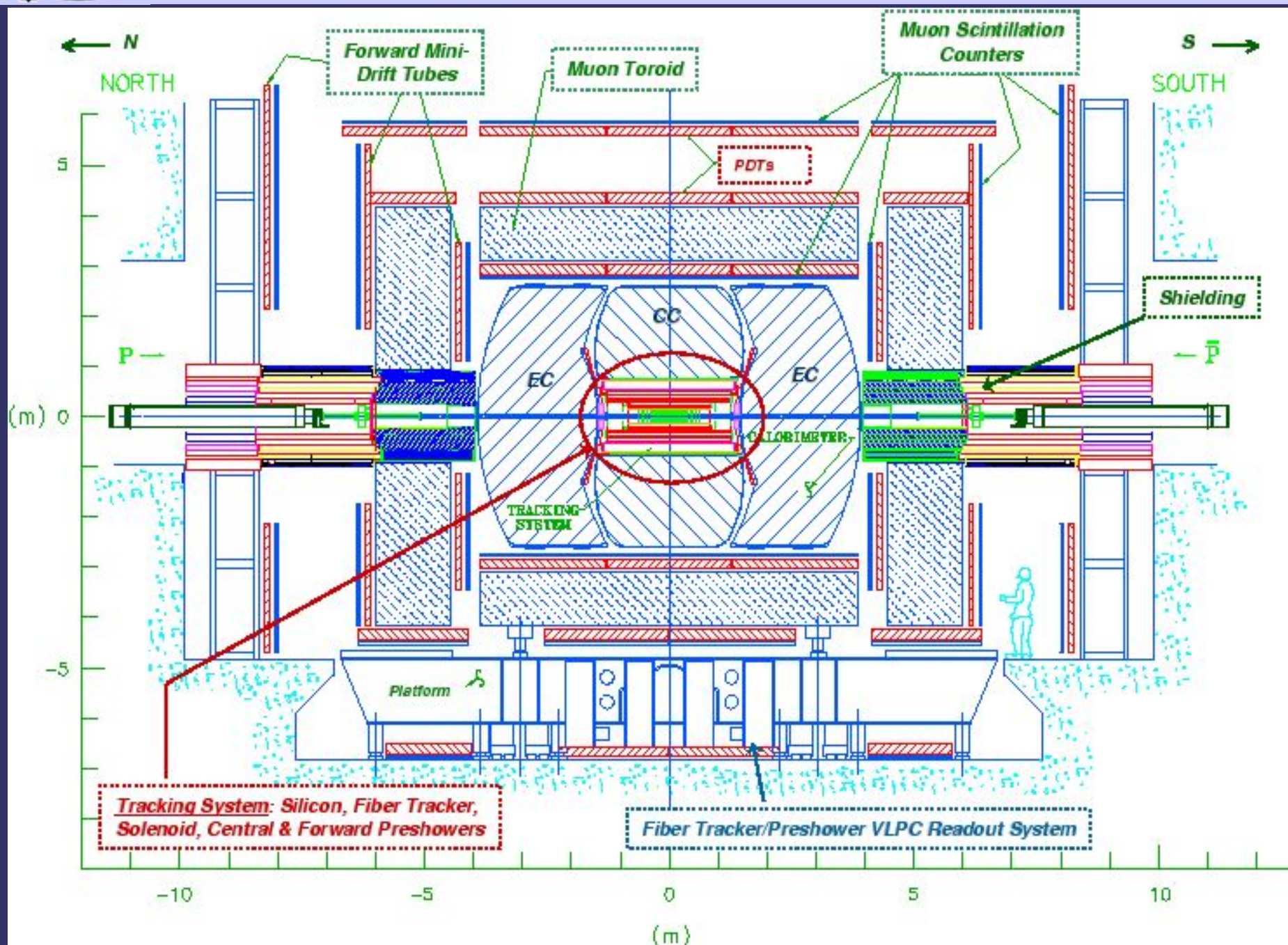



# DØ Calorimetry

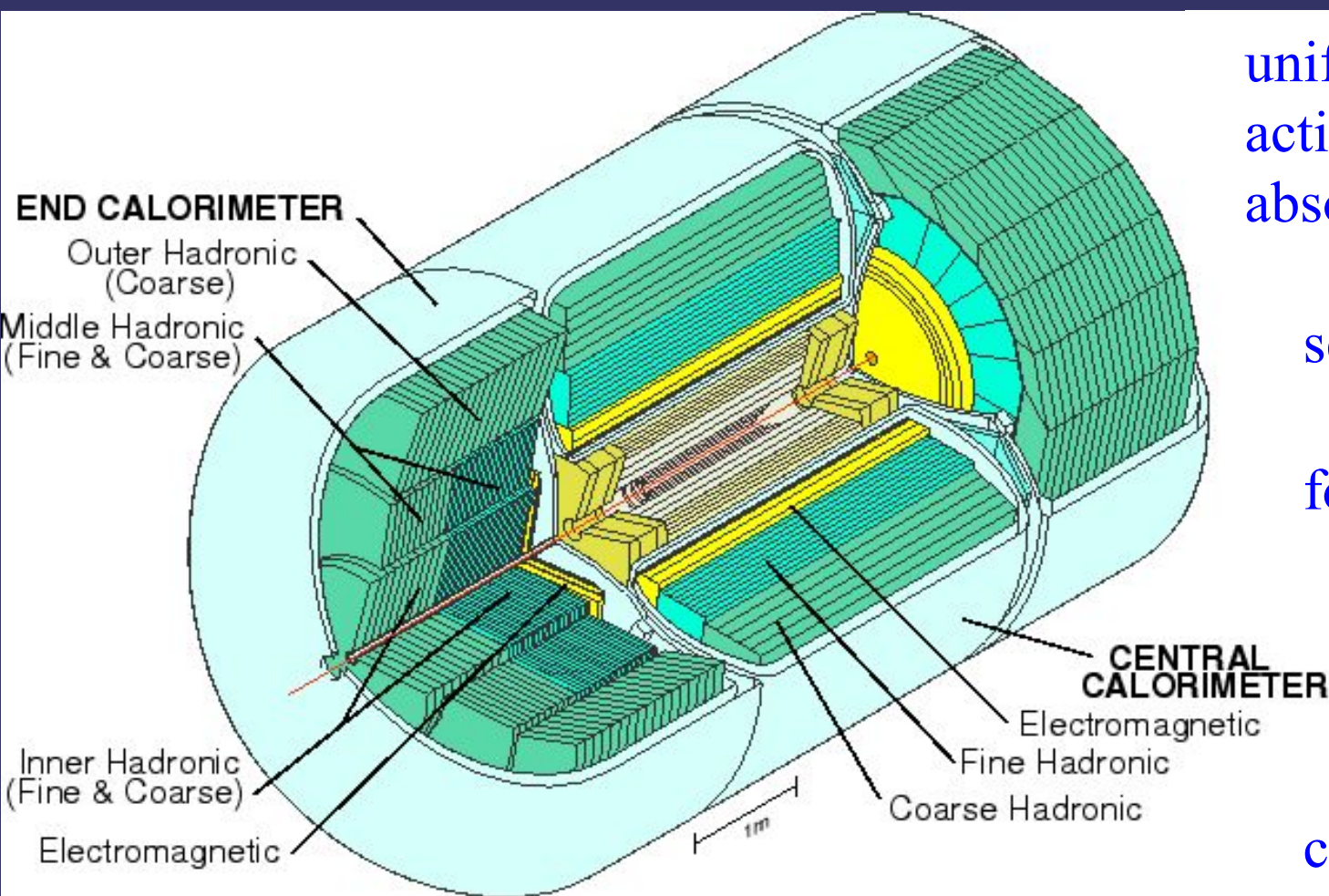

uniform and hermetic  
active material: liquid Argon  
absorber: Uranium

segmentation:

$\Delta\eta \times \Delta\phi = 0.1 \times 0.1$   
for EM showers max.:  
 $0:05 \times 0:05$

coverage up to  $|\eta| < \sim 5$

## Run II upgrades:

shorter bunch crossing times  $\rightarrow$  396 ns  $\rightarrow$  faster trigger and readout electronics  
more material before calorimeter  $\rightarrow$  magnet, tracker, new pre-shower detector  
**effectively a new detector**



# Jet Physics at DØ at $\sqrt{s}=1.96$ TeV

RunII  $d\sigma/dp_T \sim 5x$  higher for jets w/  $p_T > 600$  GeV (vs.  $\sqrt{s}=1.8$  TeV)

Higher statistics important for:

- better determination of proton structure at large  $x$
- testing pQCD at a new level (resummation, NNLO theory, NLO event generators)
- continued searches for new physics while testing distances  $\sim 10^{-19}$  m
- compositeness,  $W'$ ,  $Z'$ , extra dimensions etc...
- understanding primary backgrounds to new physics, production dynamics affecting precision measurements, etc.

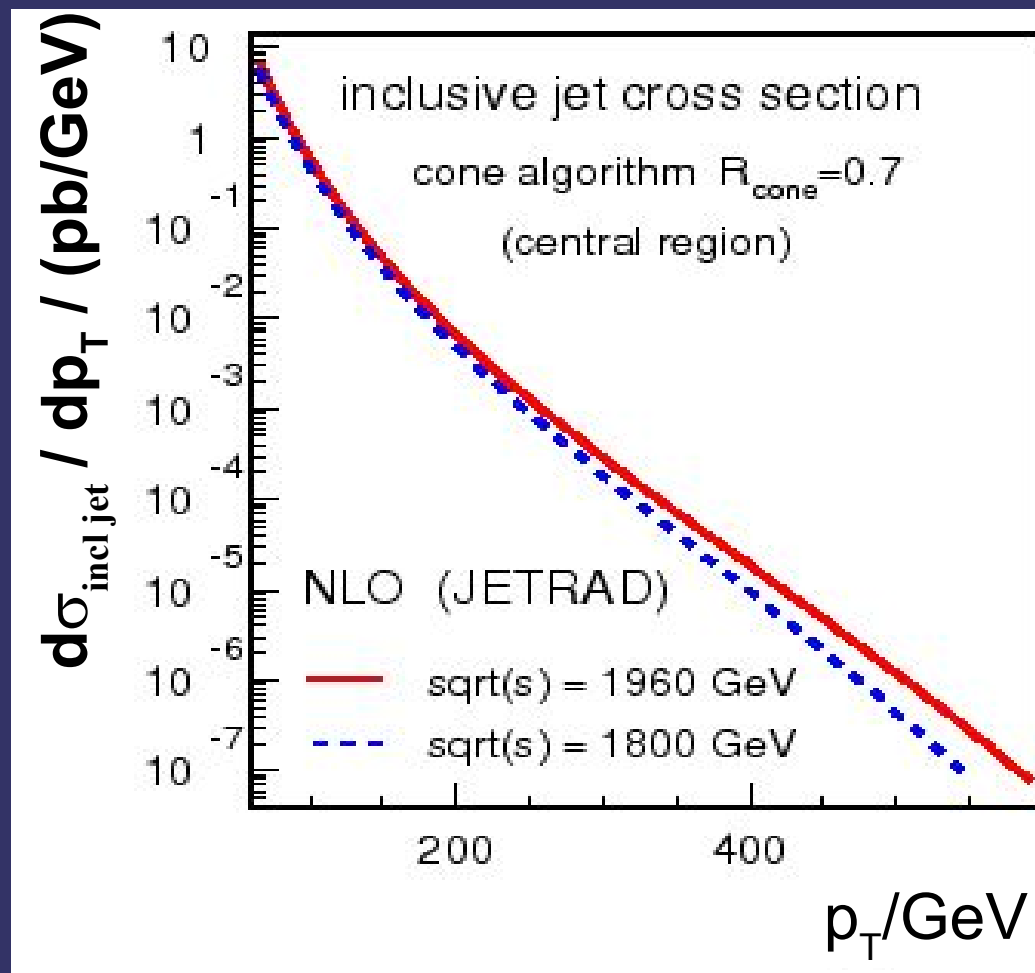



# IR Safe Cone Jet Definitions in Run II

- Modifications for Run II:
  - Use 4-vector scheme,  $P_T$  instead of  $E_T$
  - Add midpoints of jets as additional starting seeds
  - Infrared safe

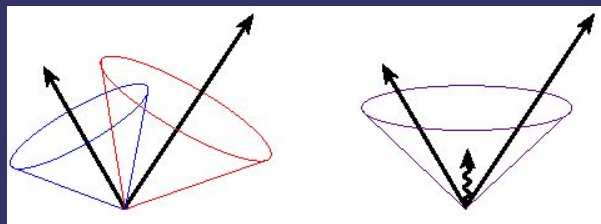

(For details on RunII jet algorithms, see [hep-ex/0005012](http://hep-ex/0005012) + recent talk by B. Andrieu at ISMD 2004)

- Correct to particle energies
  - Offset: Underlying event, previous/extra interactions
  - Energy response (from  $\gamma$ +jet events)
  - Energy loss out of cone due to showering in the calorimeter
  - Resolution (unsmearing)

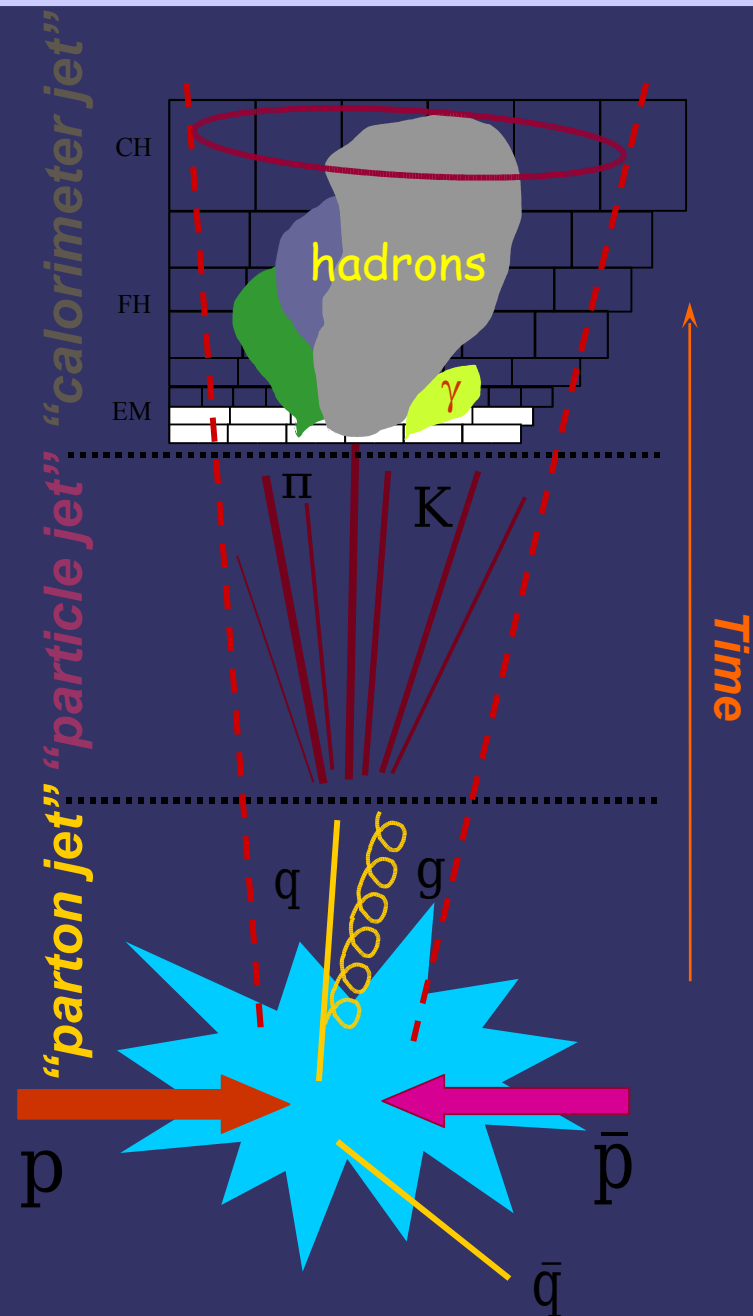



# Inclusive Jet Cross Section: Run II Cone

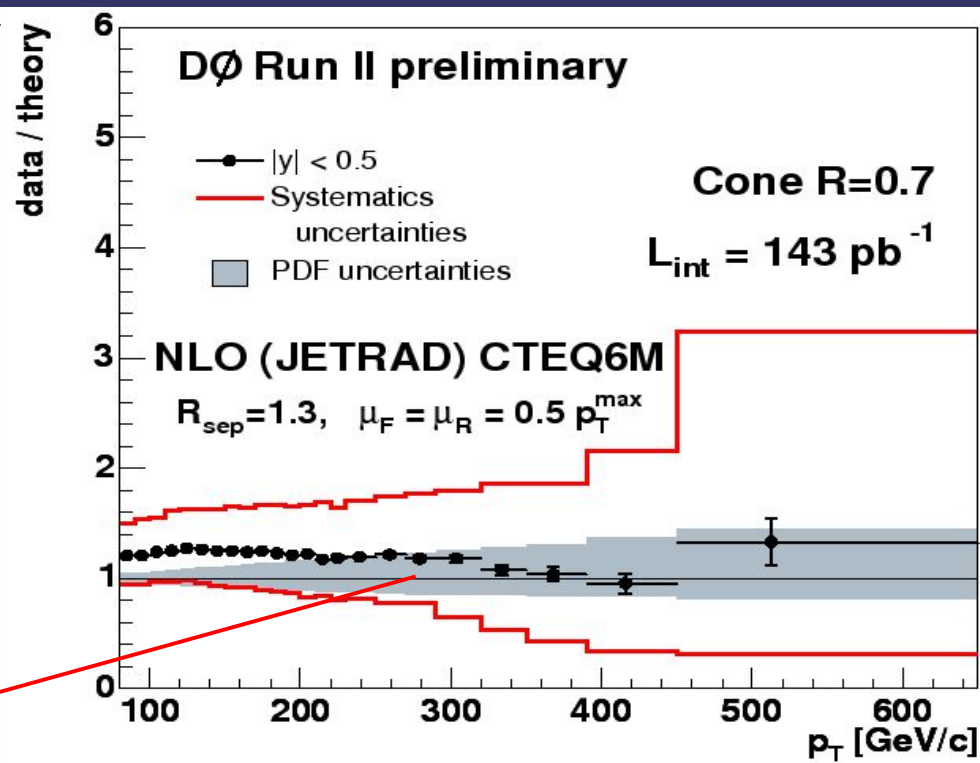
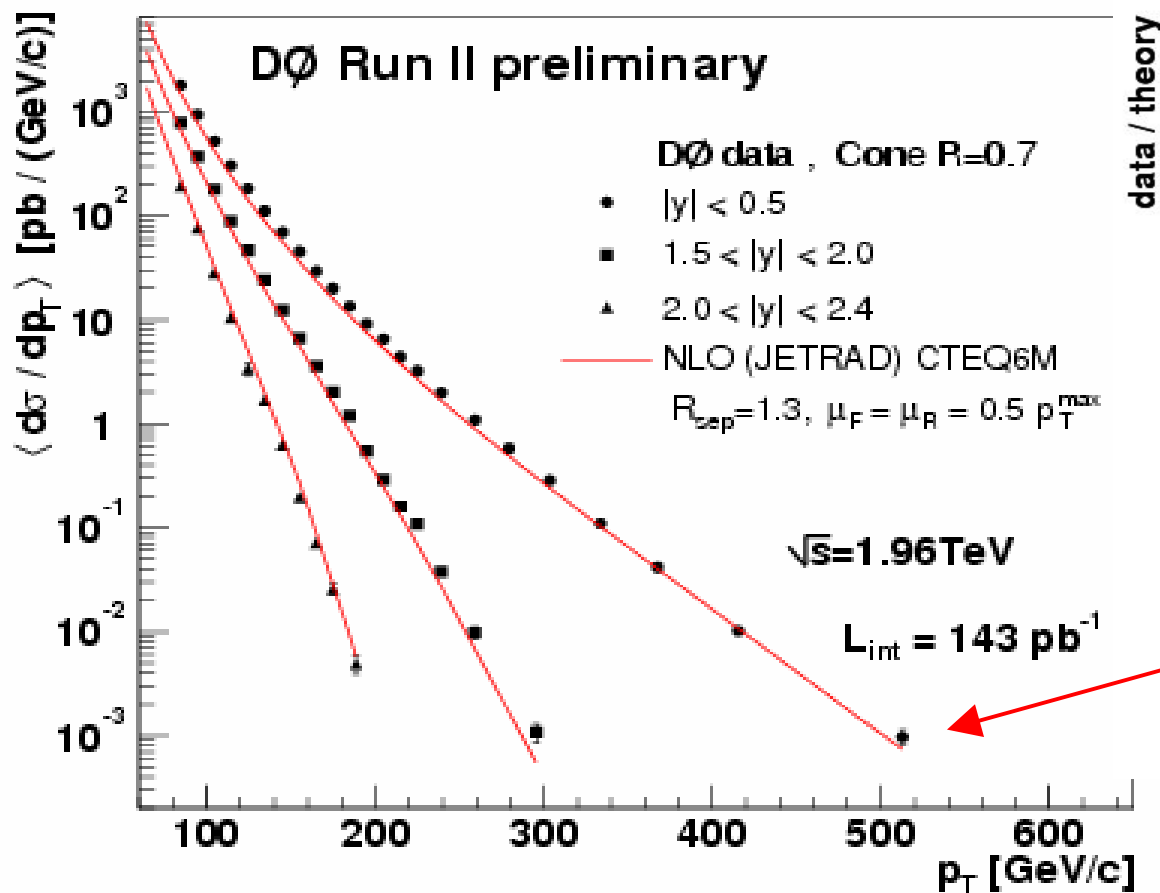

Systematic errors dominated by uncertainties in jet energy scale

Scale is determined in-situ, improvements with integrated luminosity ( $\gamma$ +jet statistics), refined cell-level calibrations, studies of showering effects (particularly in forward regions)



# Inclusive Jet Cross-Section vs. Rapidity

$2 < |y| < 2.4$

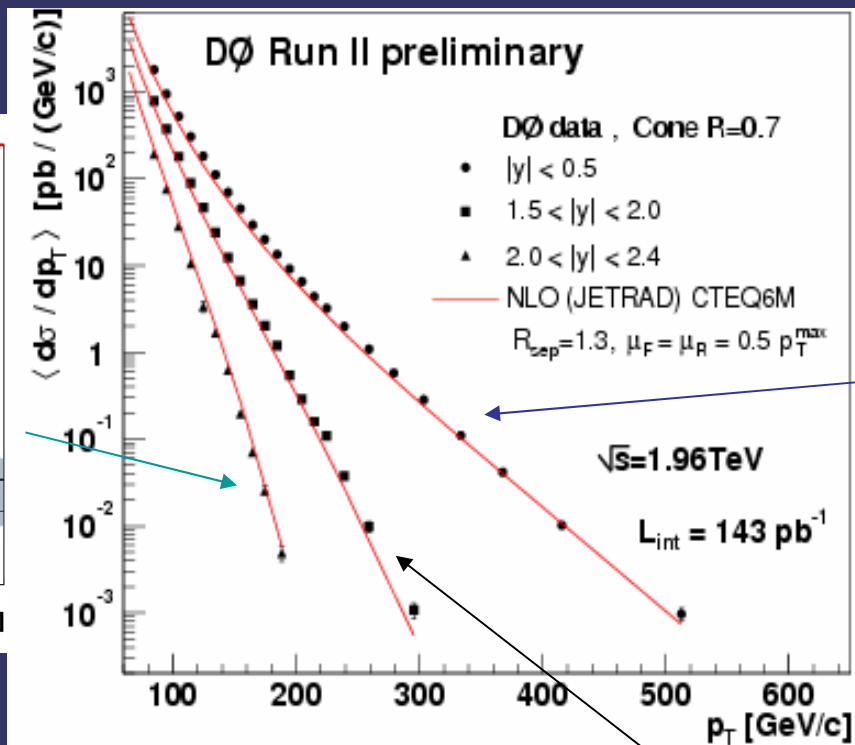
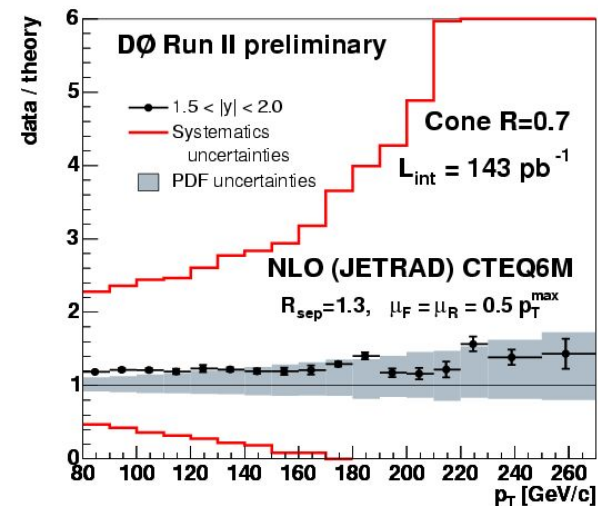

$|y| < 0.5$

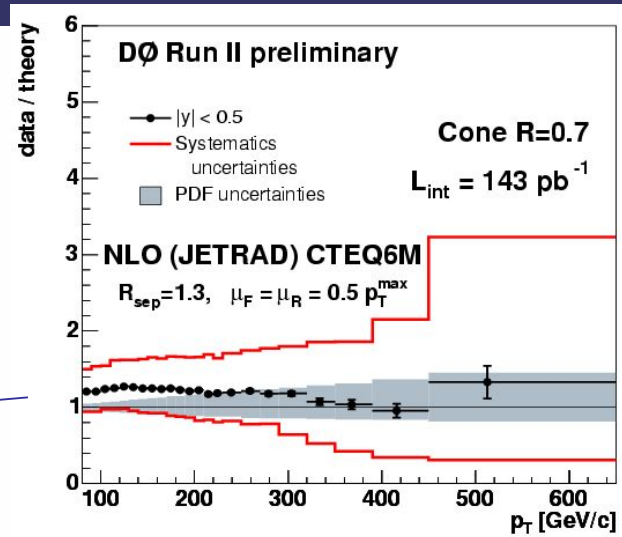

$1.5 < |y| < 2.0$

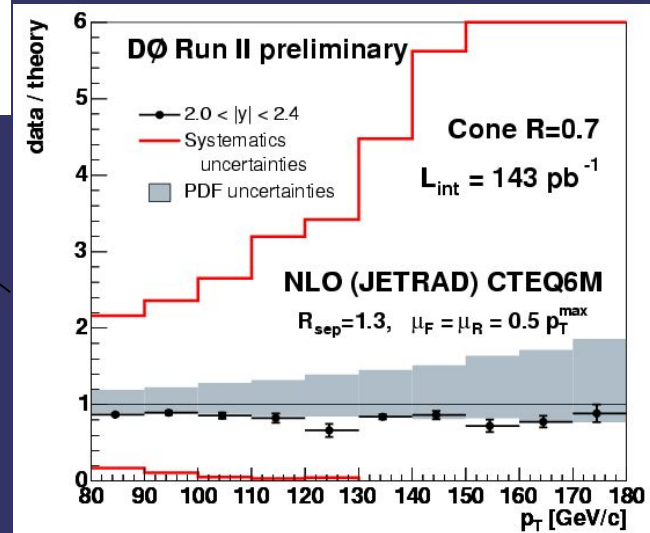

- 1st corrected Run II cross section for forward jets
- Good agreement between data and theory at all rapidities
- Important PDF information in  $\sigma$  vs. rapidity

# Substantial uncertainties in large-x gluon

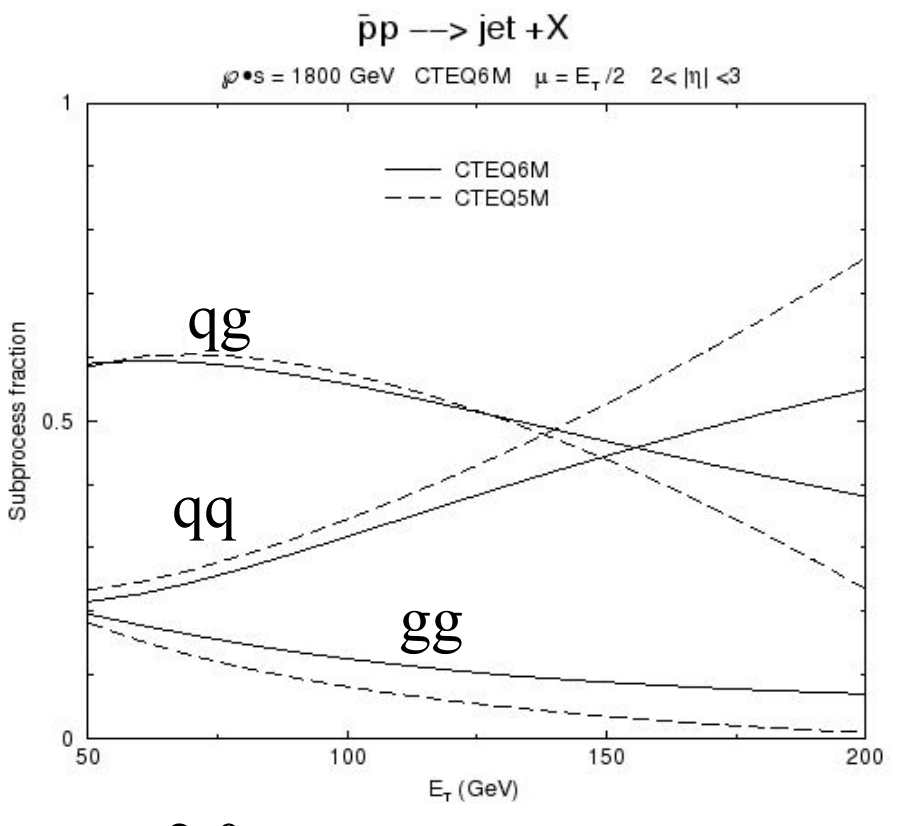

$$p \bar{p} \rightarrow \text{jet} + X$$

$$2 < |\eta| < 3$$

$$0 < |\eta| < 0.5$$

Ratio to CTEQ6 fit

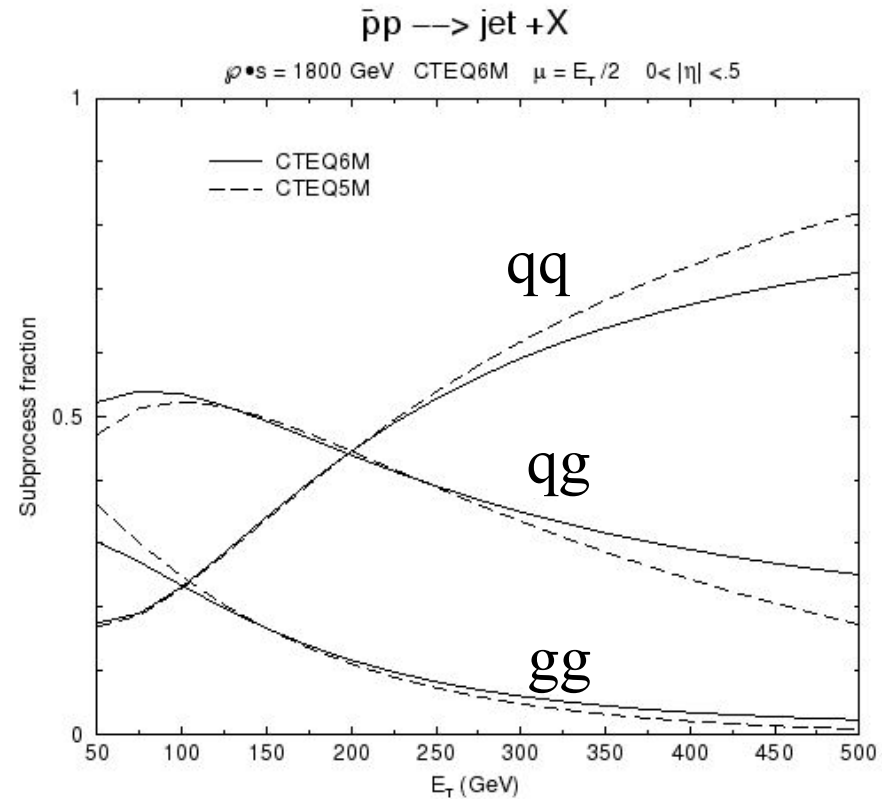
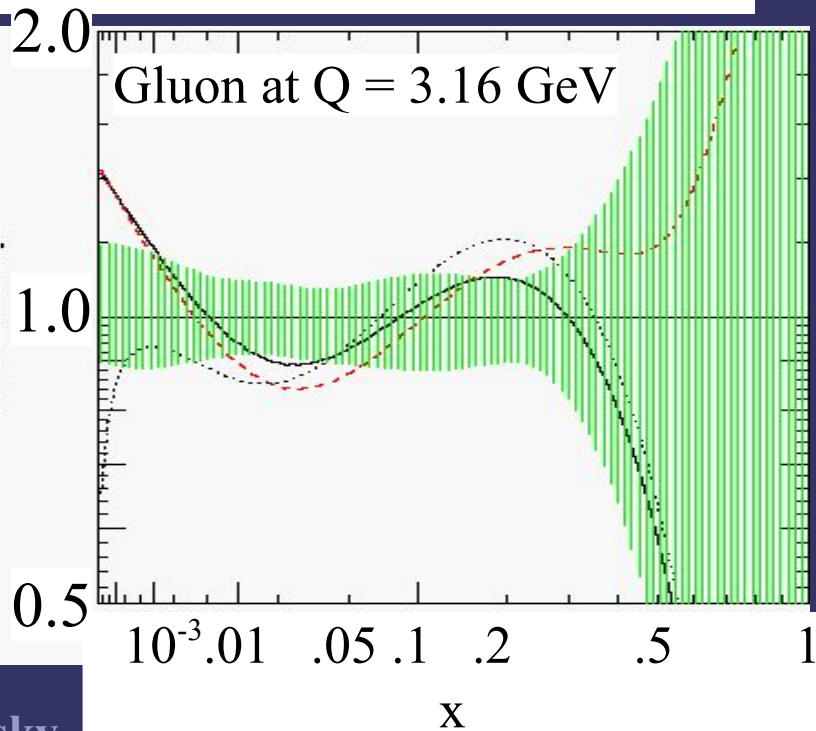



# Dijet Mass Spectrum $d\sigma/dM_{jj}$ for $|y| < 0.5$

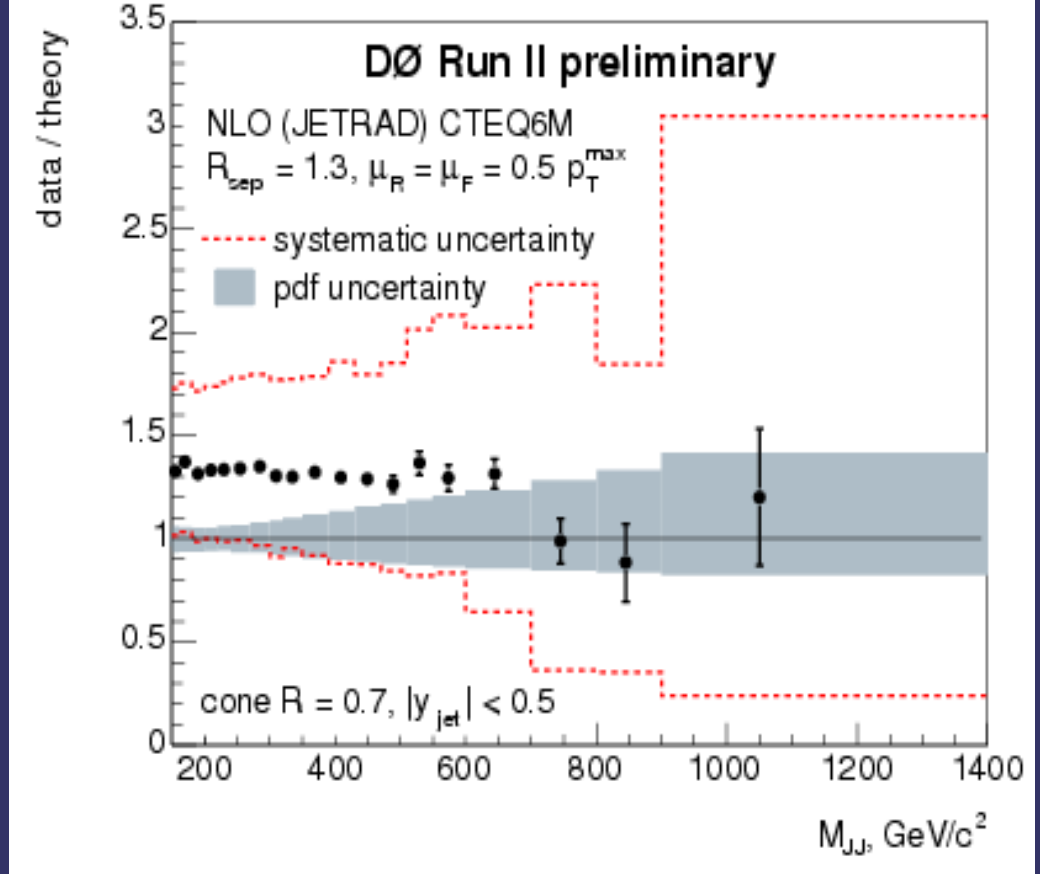
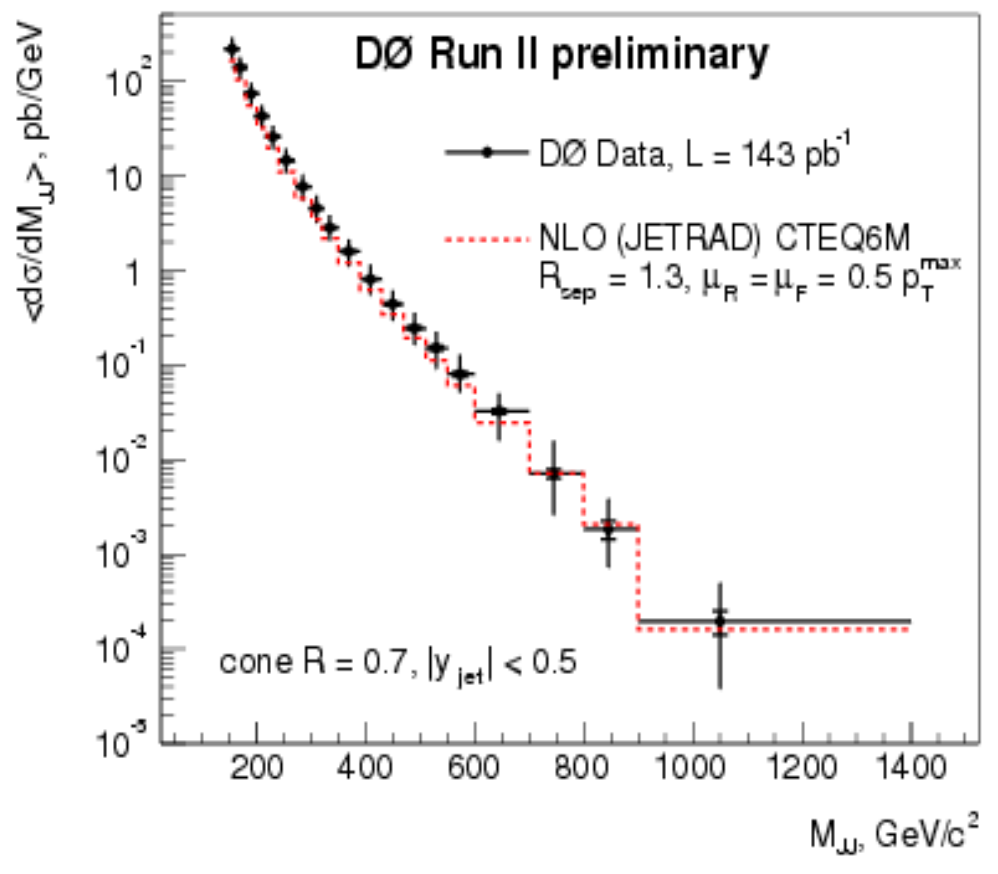

- Central region  $|y_{\text{jet}}| < 0.5$ , data sample  $\sim 143 \text{ pb}^{-1}$
- Run II midpoint algorithm
- Agreement within uncertainties with NLO/CTEQ6M
- Jet Energy Scale ( $< 7\%$ ) -- dominant error on the measurement



# Highest Mass Dijet Event From DØ

jet 1	jet 2
$p_T = 616 \text{ GeV}$	$p_T = 557 \text{ GeV}$
$y = -0.19$	$y = 0.25$
$\phi = 0.65$	$\phi = 3.78$
$M_{jj} = 1206 \text{ GeV}$	
Run 178796 Event 67972991 Fri Feb 27 08:34:03 2004	

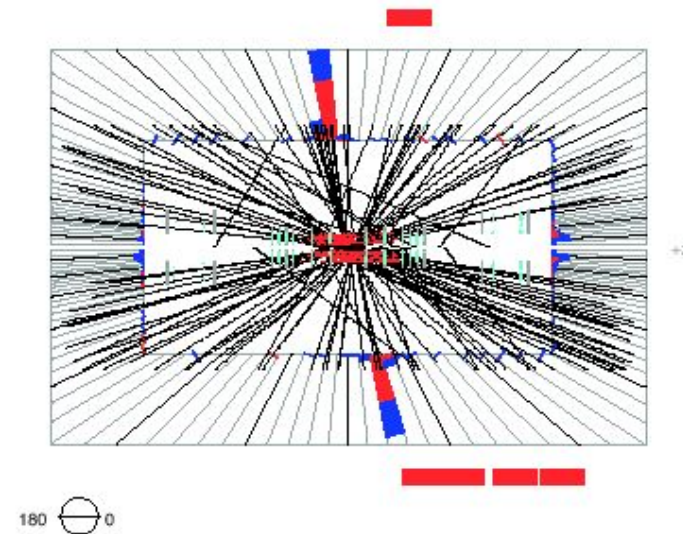
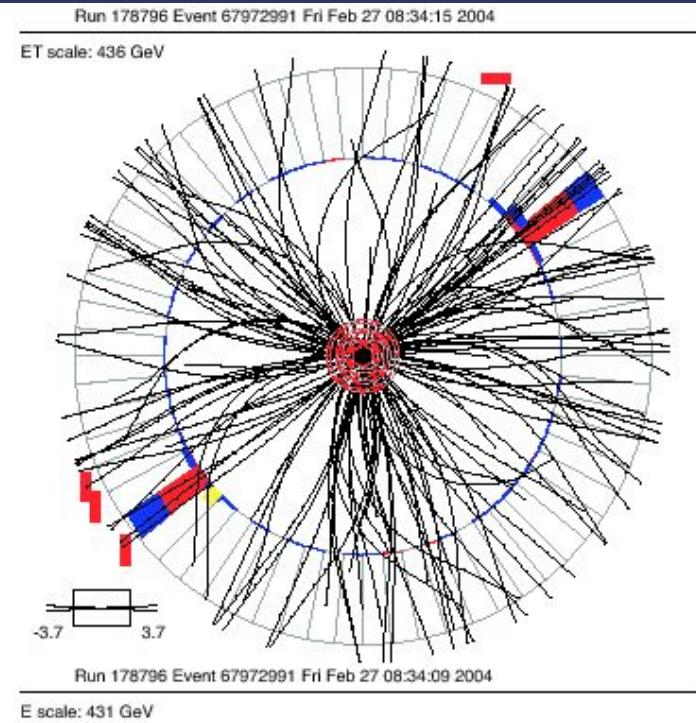
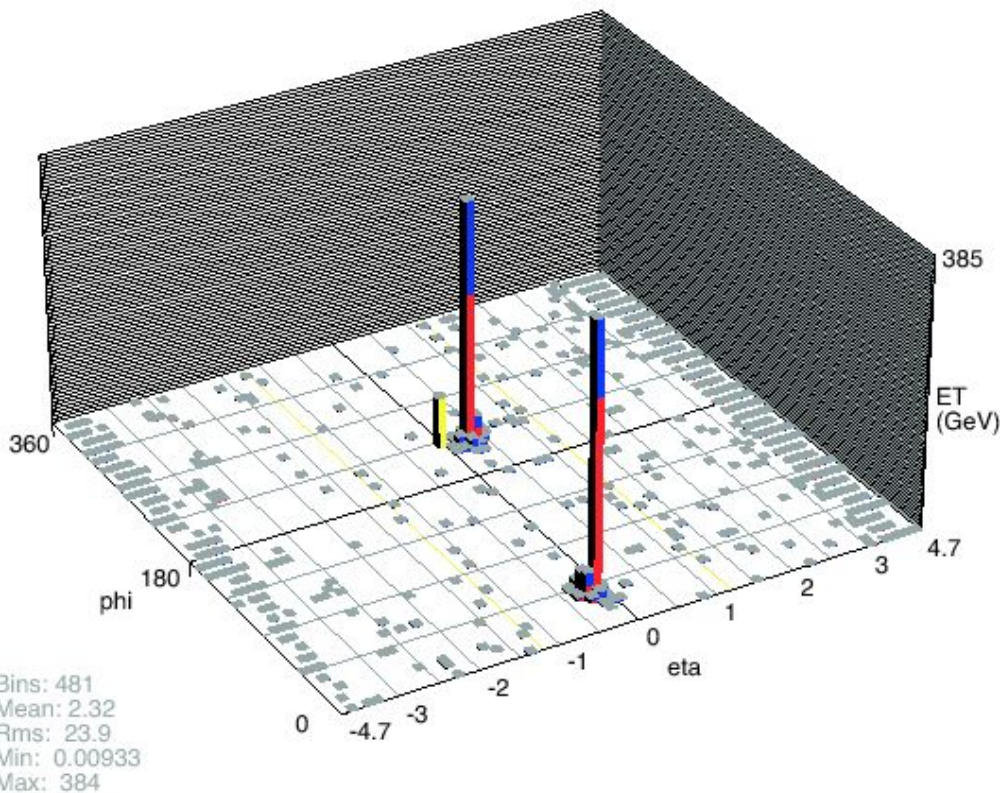



# Concluding Remarks

- First results show generally good agreement with theory for cross-sections
- Increasingly precise QCD measurements to be pursued in Run II
- Explore high  $P_T$  and  $M_{jj}$  regions over a wide range of rapidities
  - Direct search for evidence of new physics
  - Constrain high- $x$  gluon contributions
- QCD knowledge from Tevatron is essential for:
  - Precision measurements and searches for New Physics
  - Expectations for LHC

Substantial increases in precision are anticipated with increasing luminosity and detector characterization.