

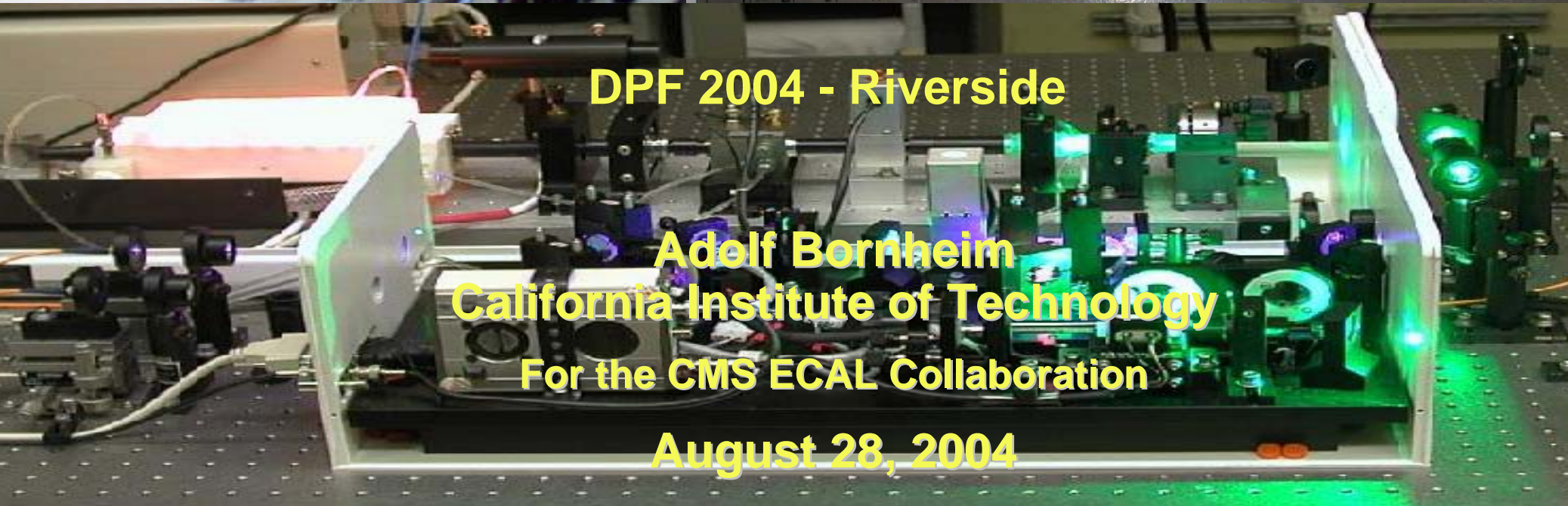

Monitoring the CMS Lead Tungstate Electromagnetic Calorimeter

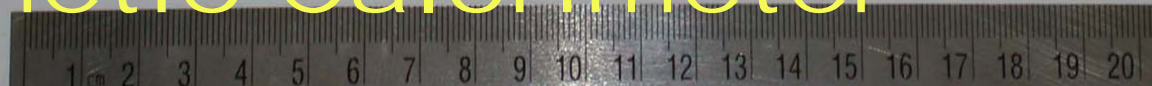

DPF 2004 - Riverside

**Adolf Bornheim
California Institute of Technology**

For the CMS ECAL Collaboration

August 28, 2004



CMS ECAL Monitoring - Beam Test Issues



➤ ECAL Calibration (Resolution : 'Constant Term of the Resolution Formula') :

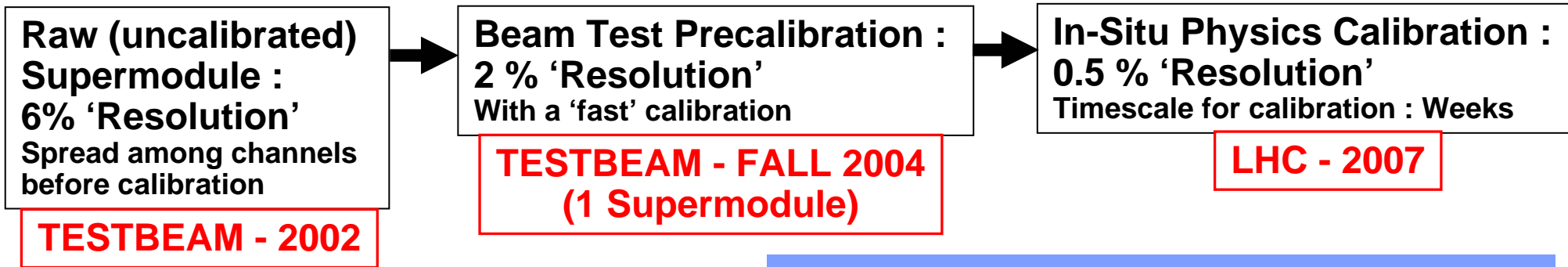

CMS ECAL Details ⇒ Georgios Daskalakis Talk

➤ ECAL Monitoring (Monitor Stability and Measure Radiation Effects) :

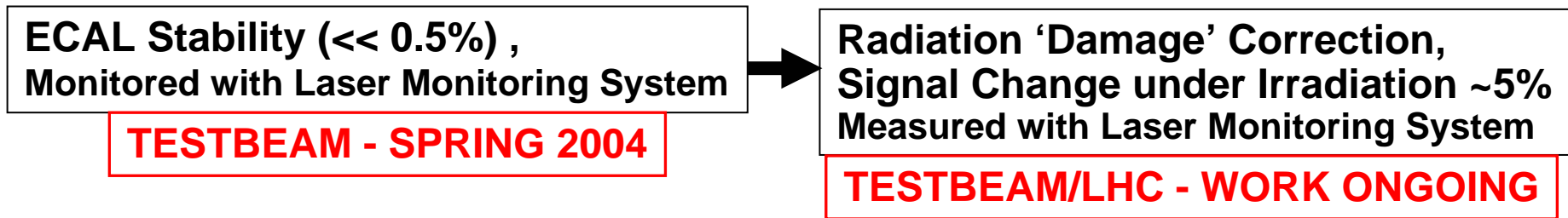

Radiation Effects in Crystals ⇒ Francesca Nessi-Tedaldi



Radiation Effects on PWO Transparency



- Radiation Reduces transmittance in the **blue** and **green**, where PWO emission spectrum peaks
- Effect is dose rate dependent.
- Monitoring **relative loss** of PWO transmittance with pulsed laser light.

For the expected dose rate at CMS barrel (15 rad/hour), transmittance loss is at a level of less than ~5%.

- Almost no effect in the **red** wavelength range.
- Monitor with red light to separate out possible variations in the other components of the light transmission and readout chain

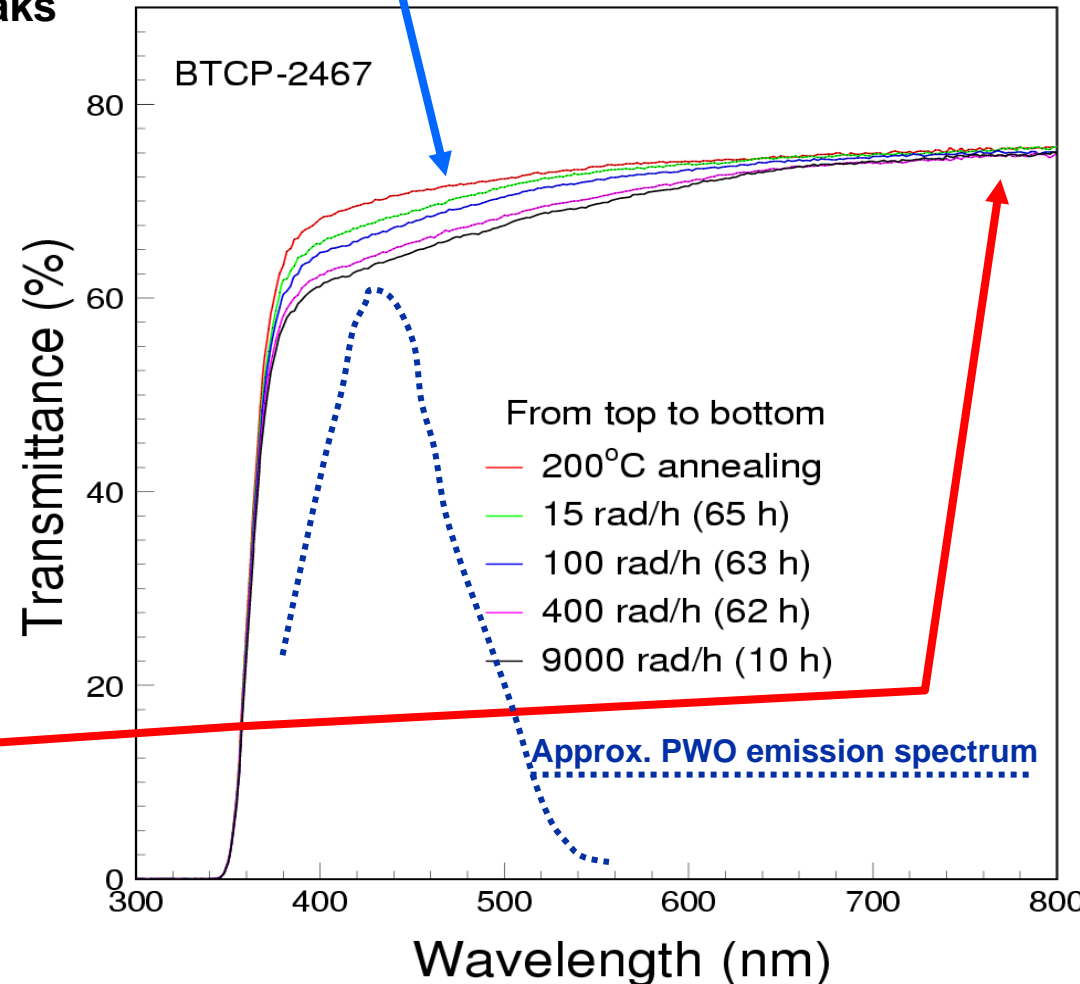



Monitoring During LHC Running

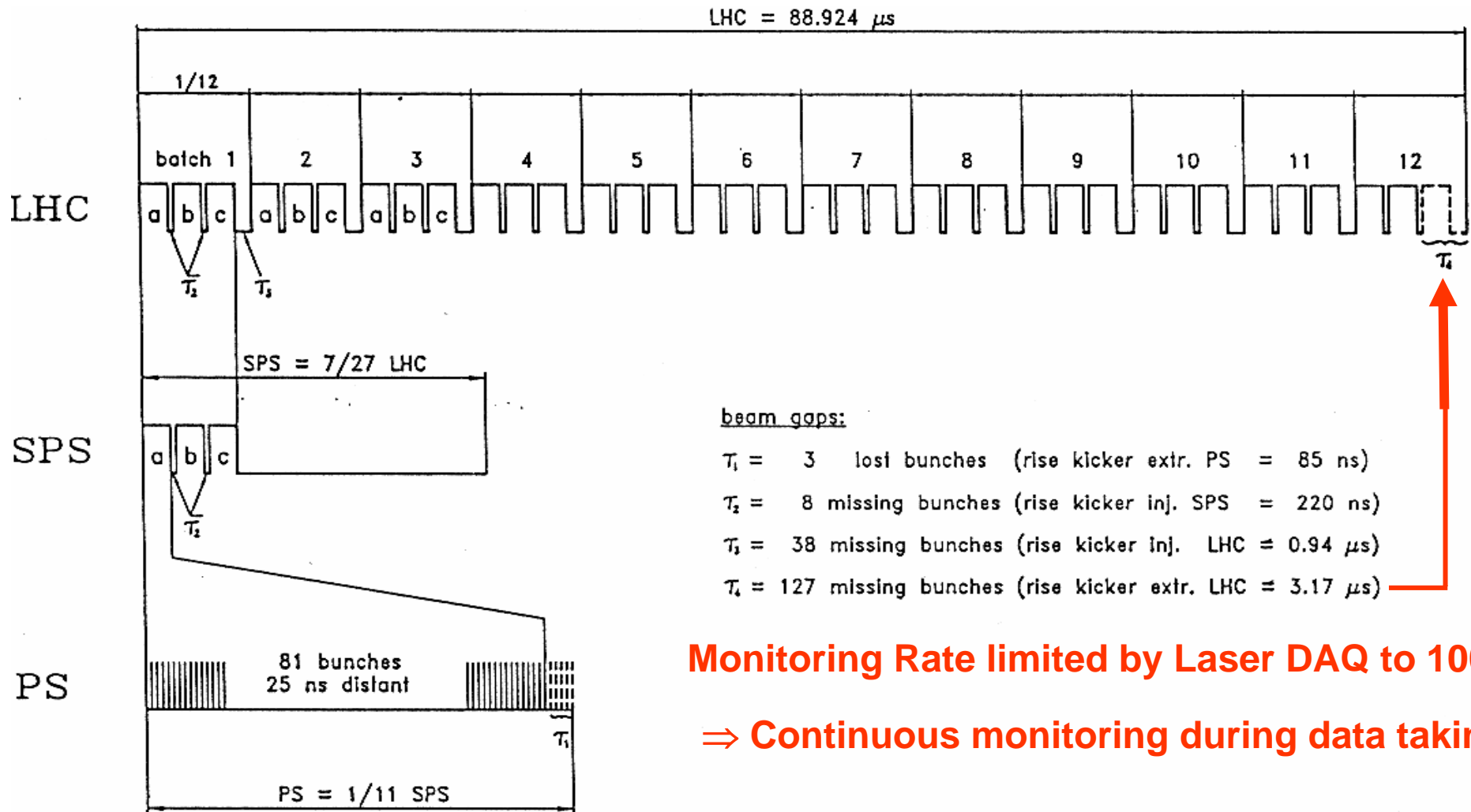

Monitoring Rate limited by Laser DAQ to 100 Hz

⇒ Continuous monitoring during data taking !



Laser Source Requirements



- **Pulse Energy : 1.0/0.6 mJ at 440nm/495nm**
Enough light to flash several hundred crystals at a time.
- **Pulse Energy Stability: ECAL specification < 10 % RMS**
Small enough to avoid possible non-linearities in the APD/PN ratio.
- **Pulse Width : ECAL specification < 40 ns**
Match shaping time of the electronics (40ns).
- **Pulse Timing Jitter : long/short term typically <4 ns / < 2 ns**
Ensure precise timing in LHC 25 ns cycle.
- **Wave Length :**
440 nm primary wavelength, 495 nm systematic cross check
800 nm / 700 nm check outside transparency change sensitive region



CMS ECAL Laser Source Layout at CERN



Monitor :
energy, pulse
width, timing
of pump laser
and main laser

RED Laser:
Provides **700 nm**
and **800 nm**

BLUE Laser:
Provides **440 nm**
and **495 nm**

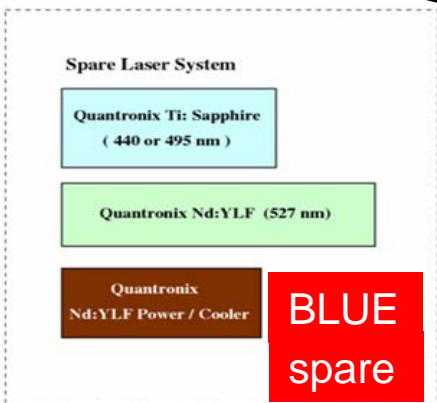
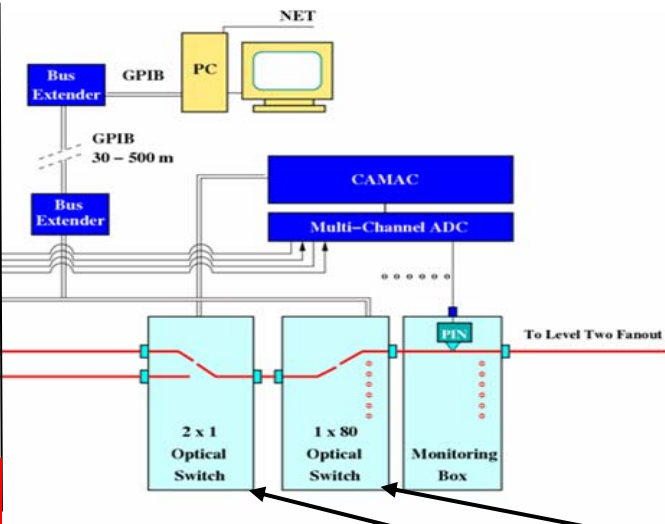
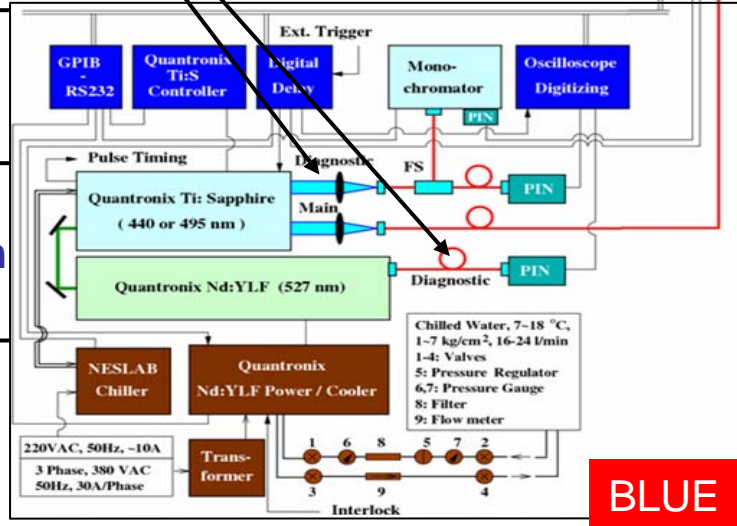
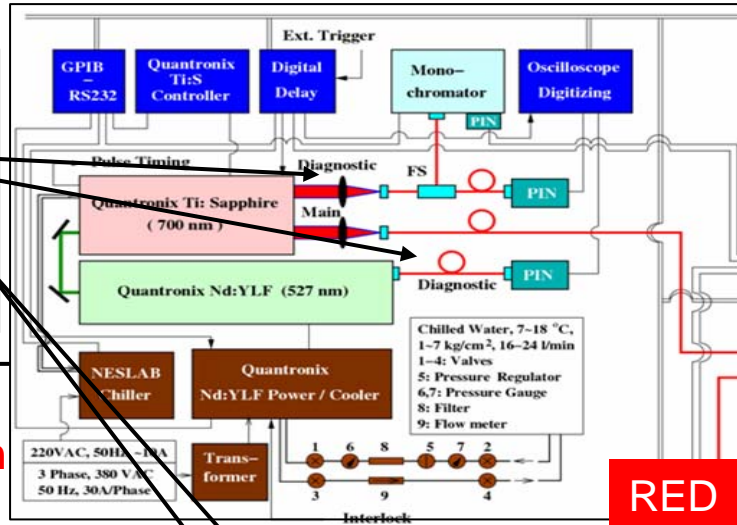

2x1 and 1x80
switch :
2x1 selects red or
blue laser,
1x80 switch selects
supermodule to be
illuminated



Caltech June 13, 2002



Ti:Sapphire Laser with Two Wavelengths



**Nd:YLF Pump
10 KW Input**

**Tunable Ti:S
100 mW Output @ 100 Hz**

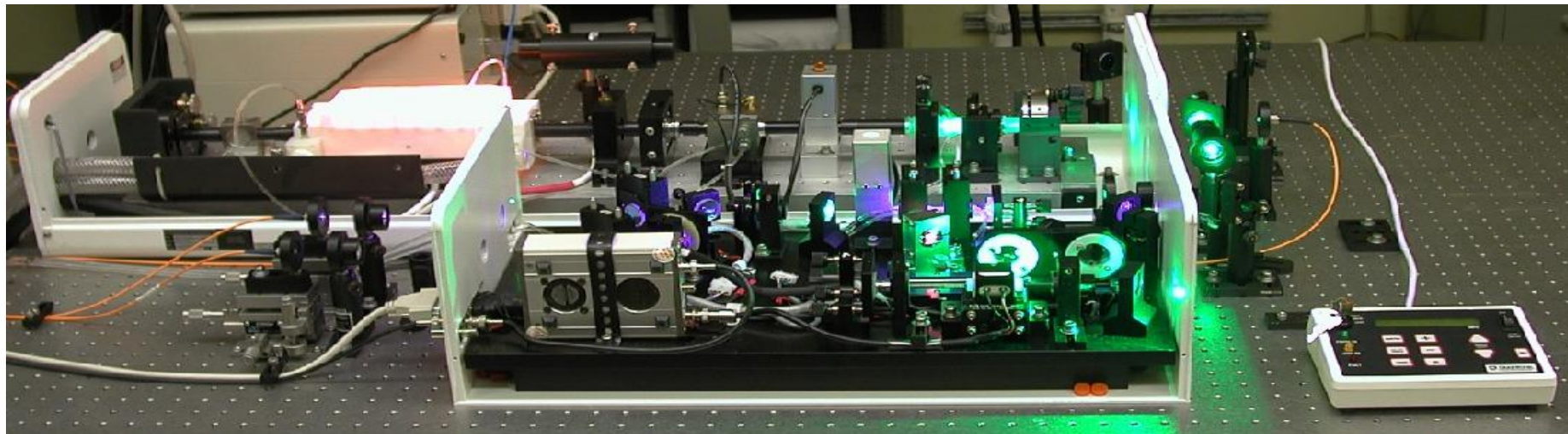
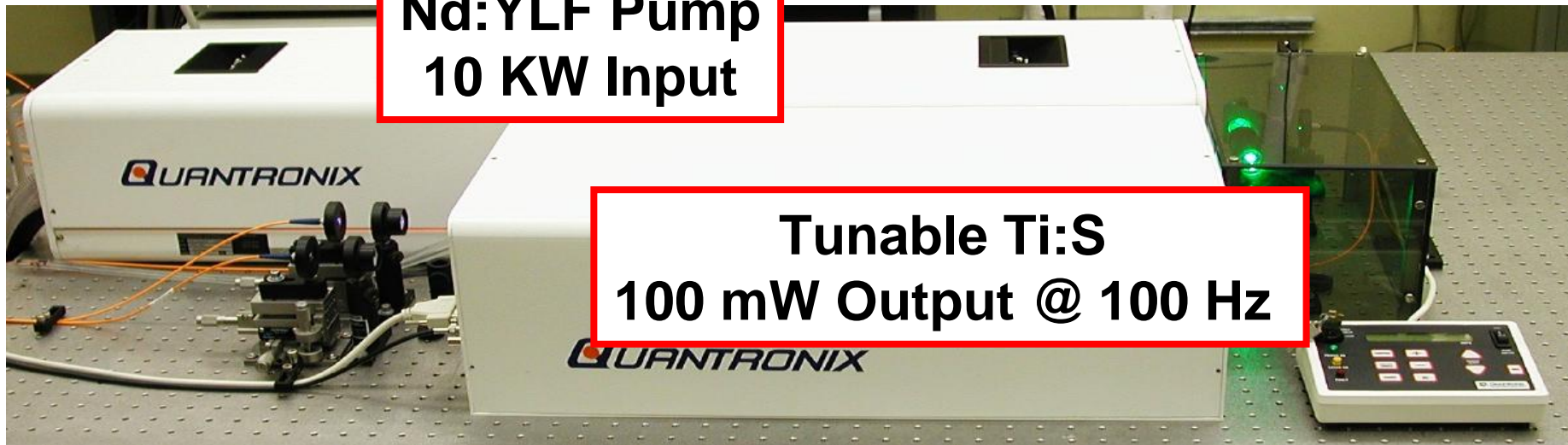



Low Level Light Distribution System

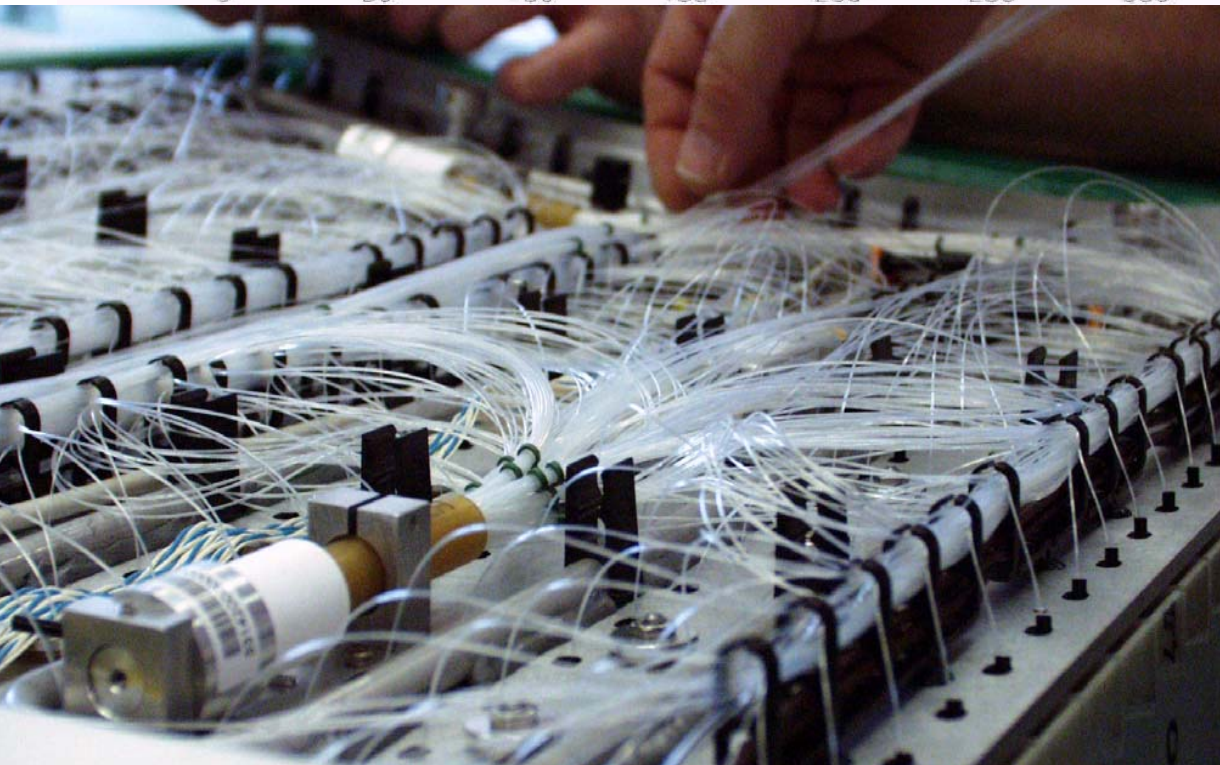
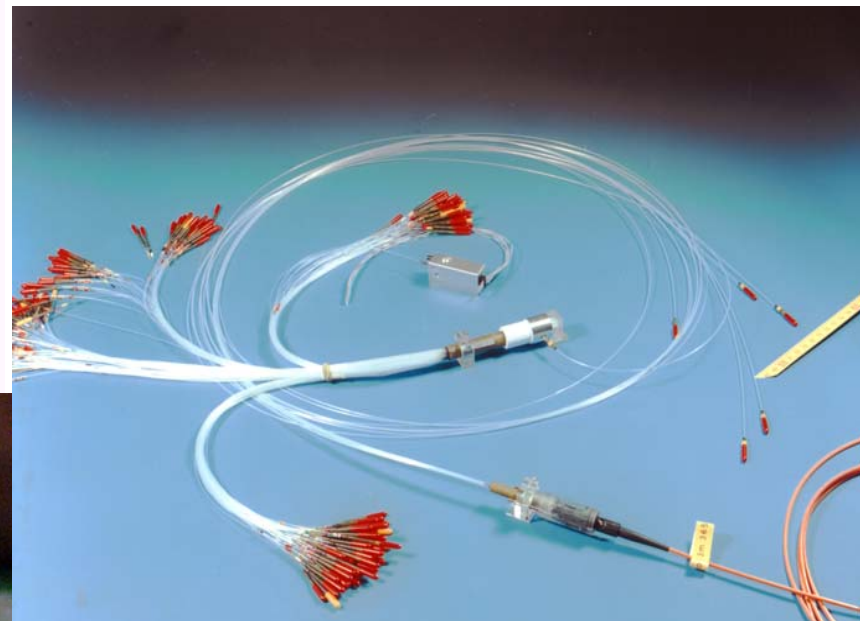
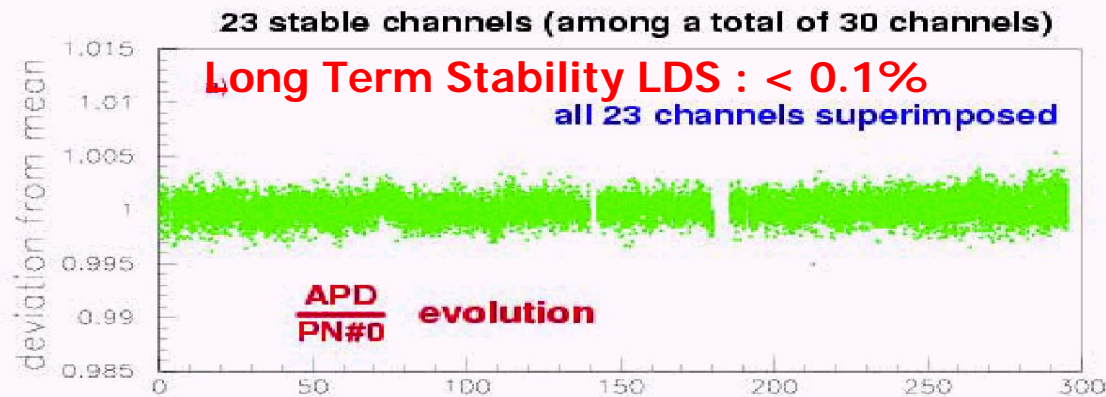



ECAL Test Beam Setup at CERN North Area

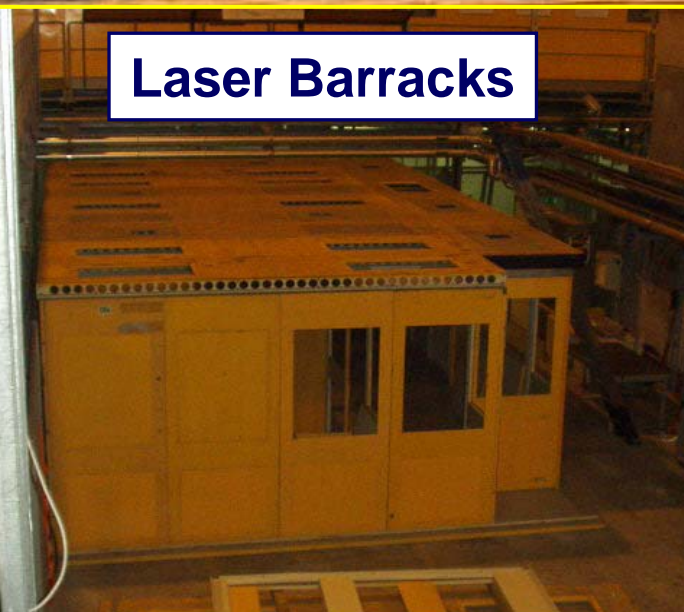
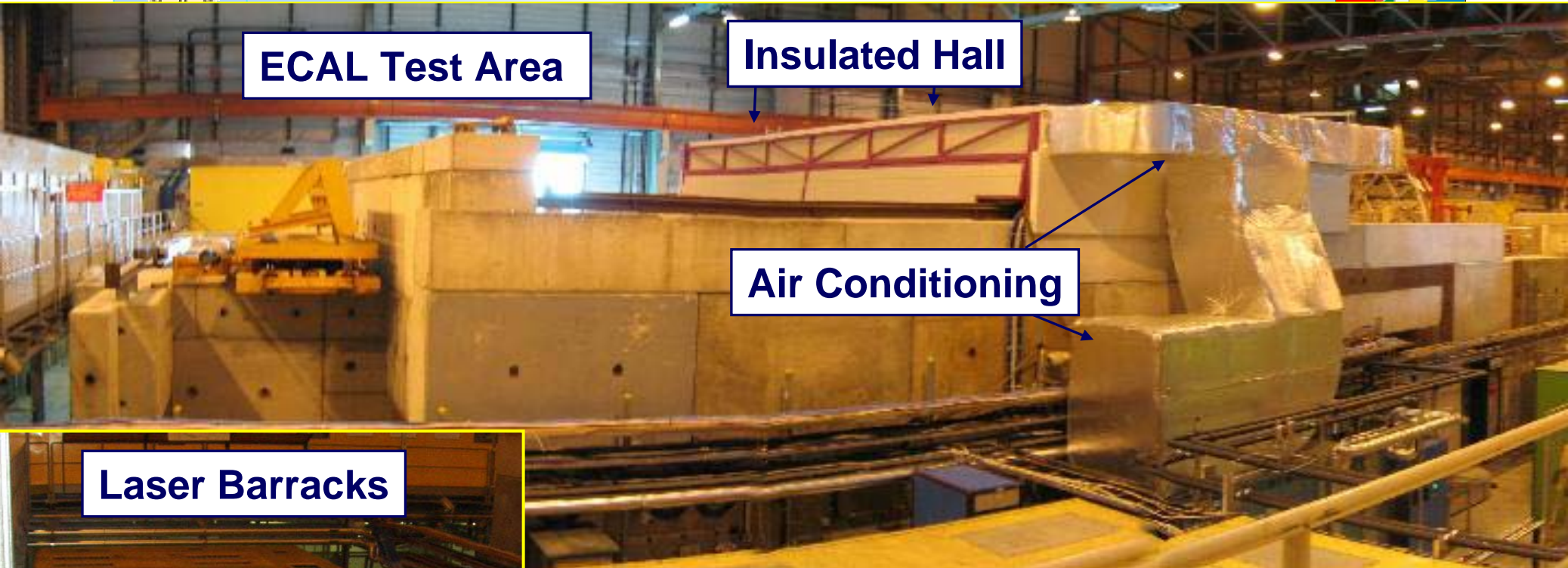

CERN ECAL Test Area
Provides a good approximation to the expected CMS environment - temperature stabilized - laser barracks separated - light transmitted via ~40 meter fiber



ECAL Test Beam Setup



ECAL Test Beam at CERN H4 :

- $\Delta p/p_{\text{BEAM}} = 0.1 \%$
- $E = 20 - 180 \text{ GeV}$, electrons/pions
- 16s/4s Test Beam Time Structure;
& 25 ns running (LHC-like timing)
- Intensity: Up to 50K events / 16s
Approx. 60 rad/hour

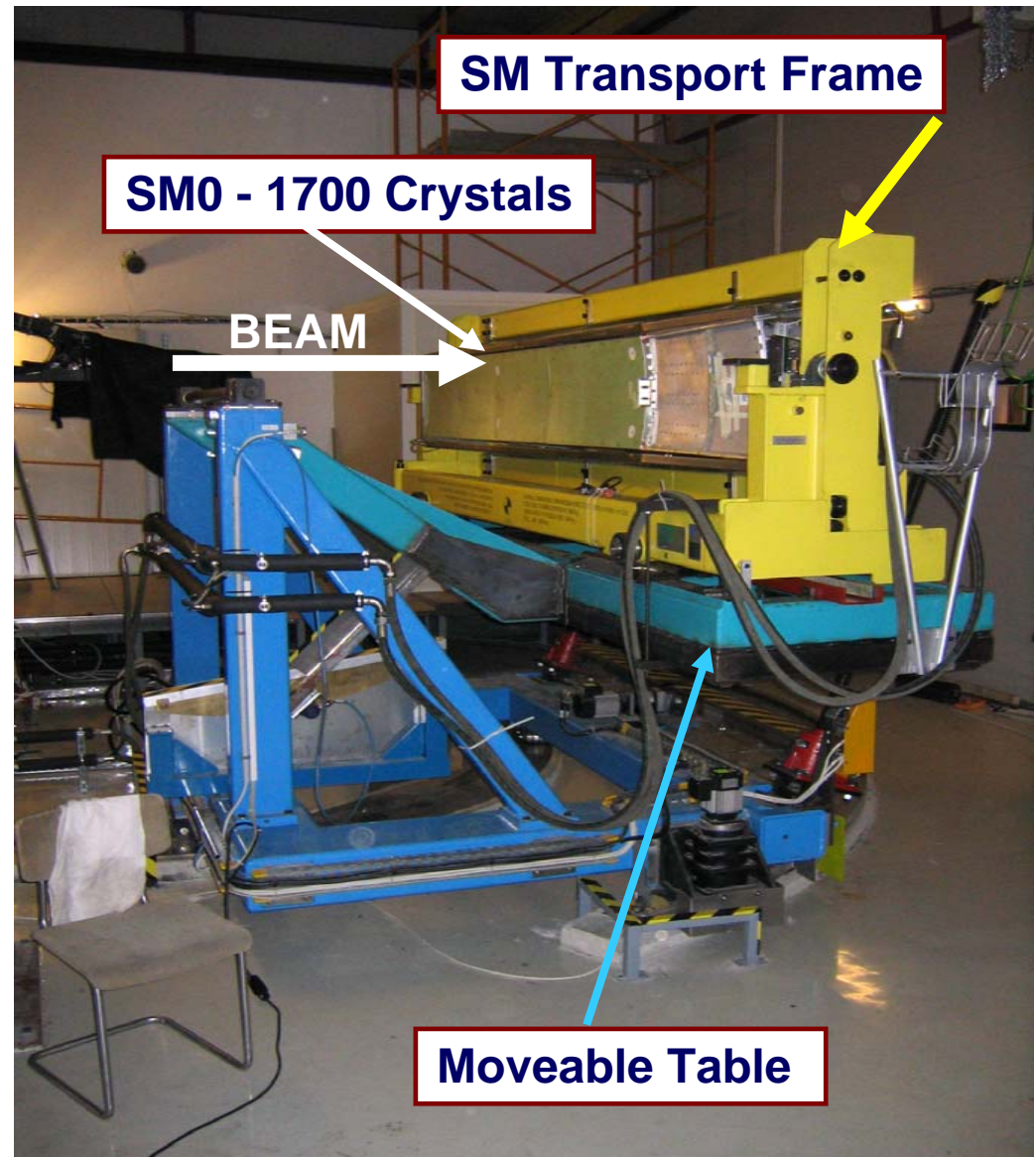



Laser Source Monitor and ECAL Monitoring



ECAL Monitoring

- Light is distributed via optical switches and a two level fanout system
- Reference diodes after each fanout. Can be pulsed electronically.
- Radiation damage is measured with respect to the reference diodes.

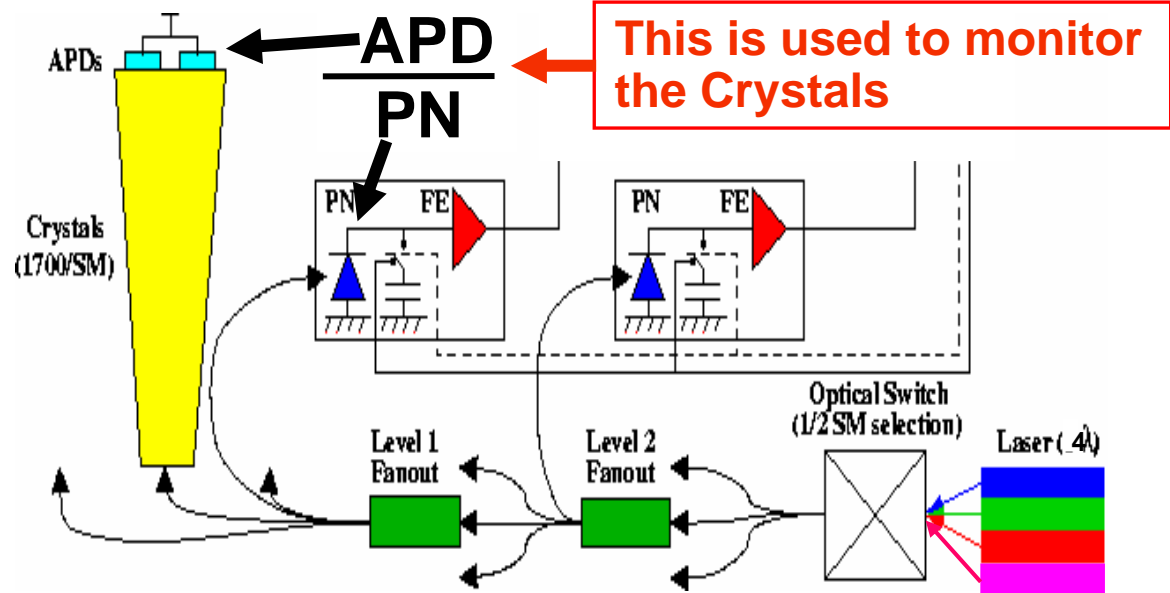

Laser Source Internal Monitor

- Each laser has a monitor output that allows to adjust and check its performance.
- Data is recorded with a separate DAQ system running at 1 Hz.
- Max. laser light pulse rate 100 Hz.

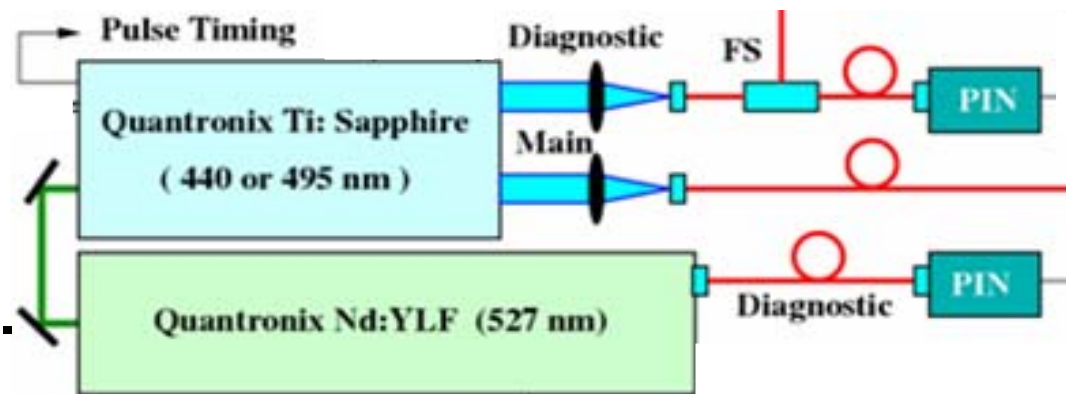



Laser Operation in 2003



Typical stable laser operation during 2003 beam test at CERN :

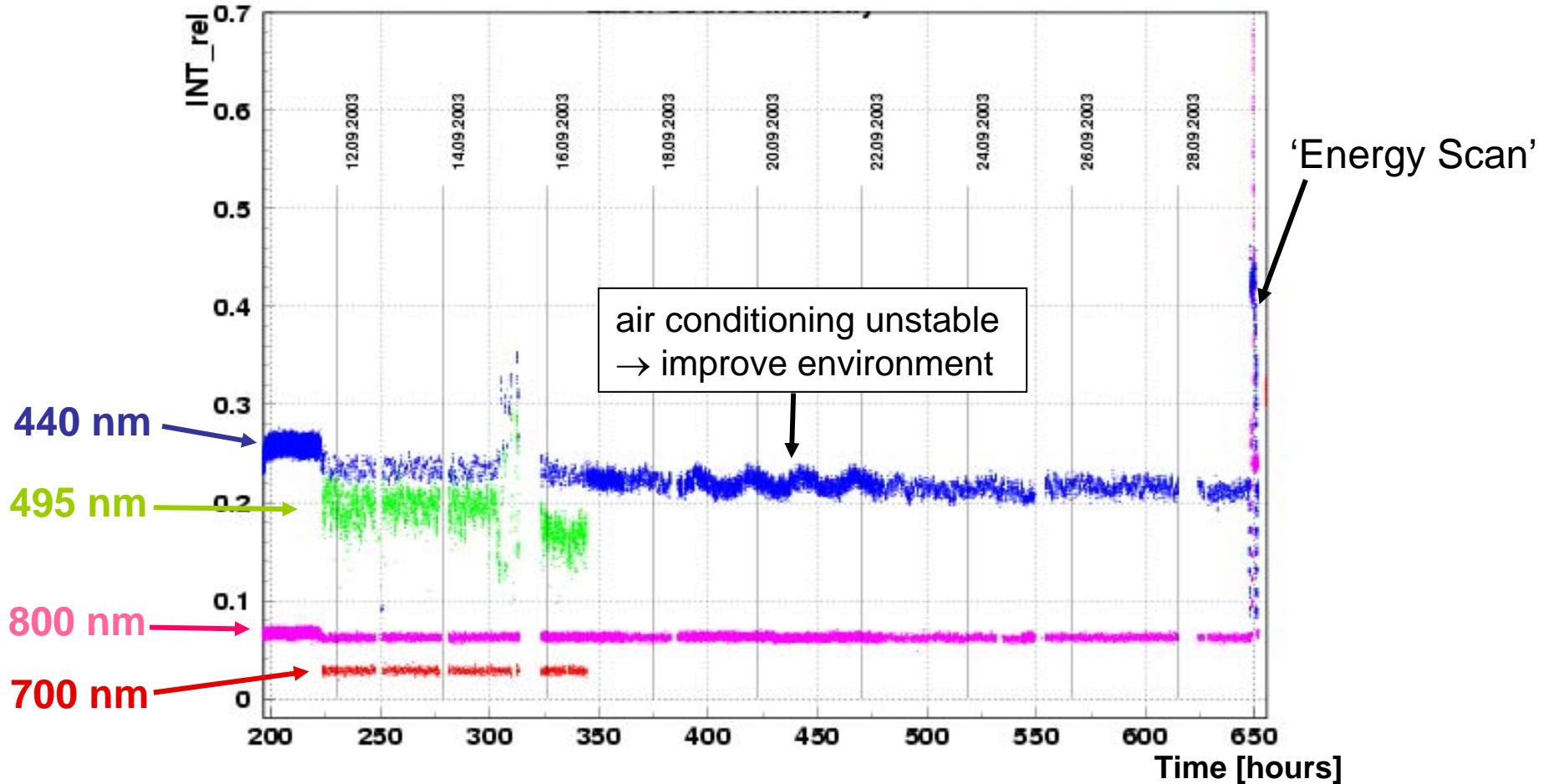

⇒ In total more than 1200 hours of operation in 2003 beam test



Laser Source Performance in 2003



Stability over 25 h

Pulse Width

Pulse Energy

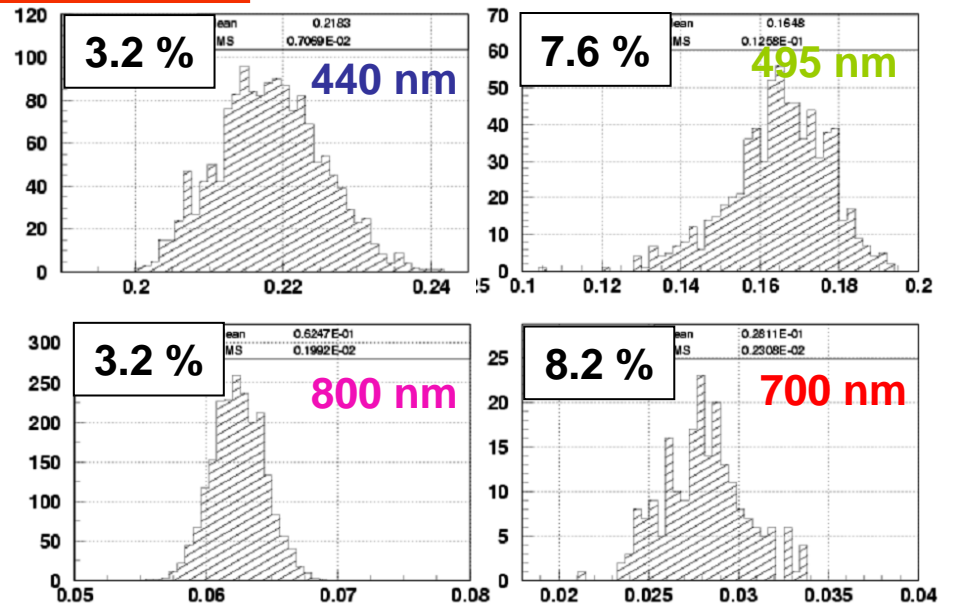
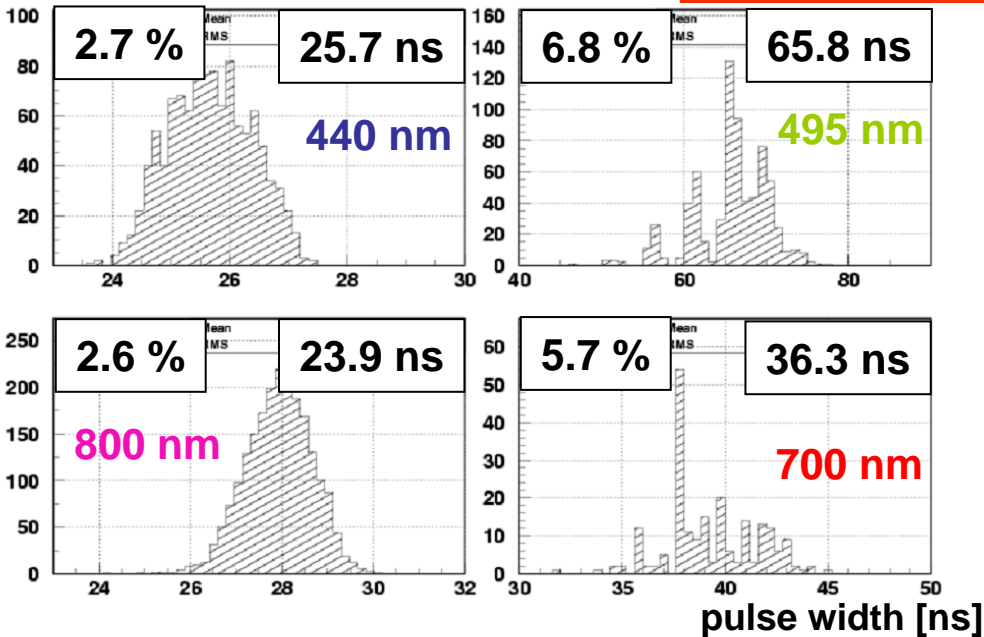

Stability over 30 min

Typical 'Laser Run' 10 - 30 minutes.

Pulse Energy - Short Term

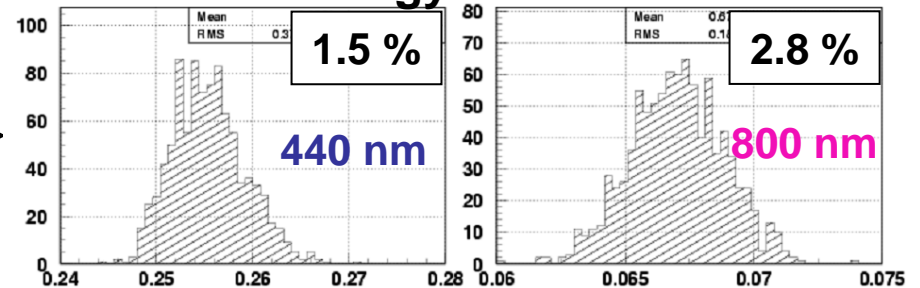

⇒ Very good performance - exceeds requirements (<10 %) !



Laser Monitoring - Long Term Stability 2003

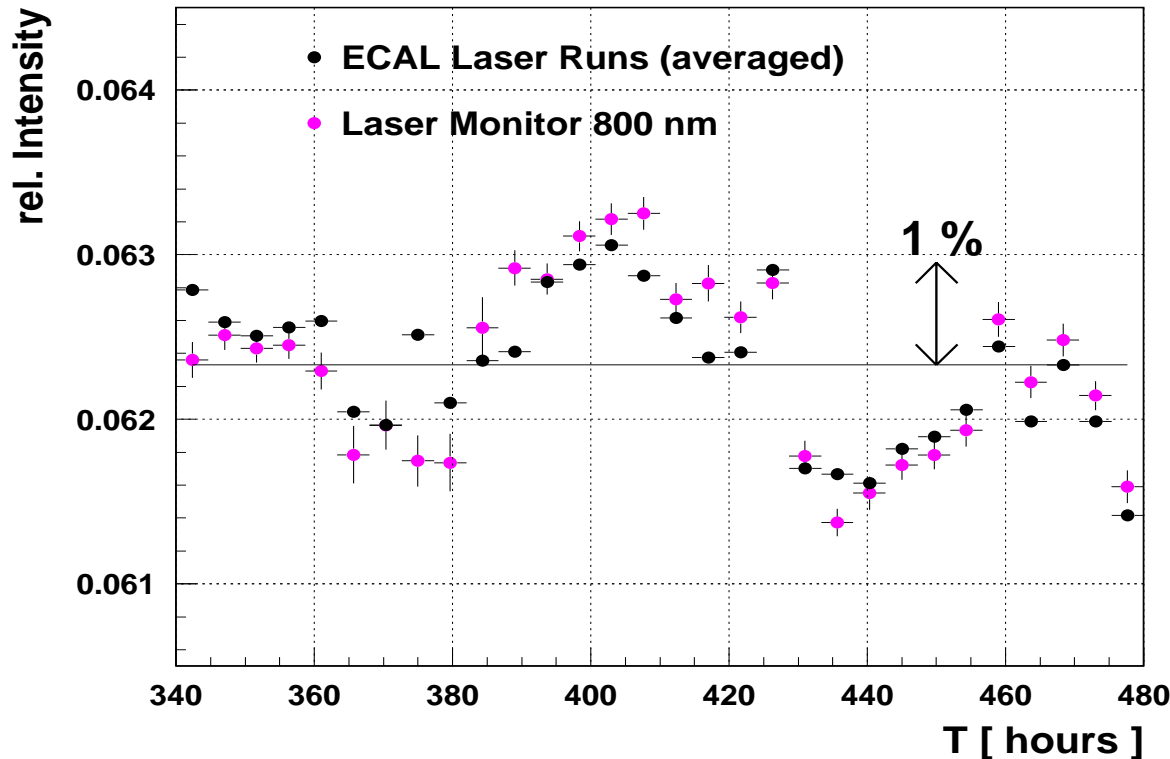

- Absolute Measurement - No Ratios
- Fully Independent Measurements
- Very good stability on an absolute scale

Monitoring entire LDS chain from the 1x2 switch onwards.

⇒ Valuable cross systematic check.

⇒ Laser source monitoring may serve as a master reference system.

⇒ Precise pulse width and timing measurement too.

➤ **Upgrades to the Laser Source monitoring DAQ to link to ECAL H4 DAQ.**



ECAL Monitoring System Stability 2004



3 days data taking without beam

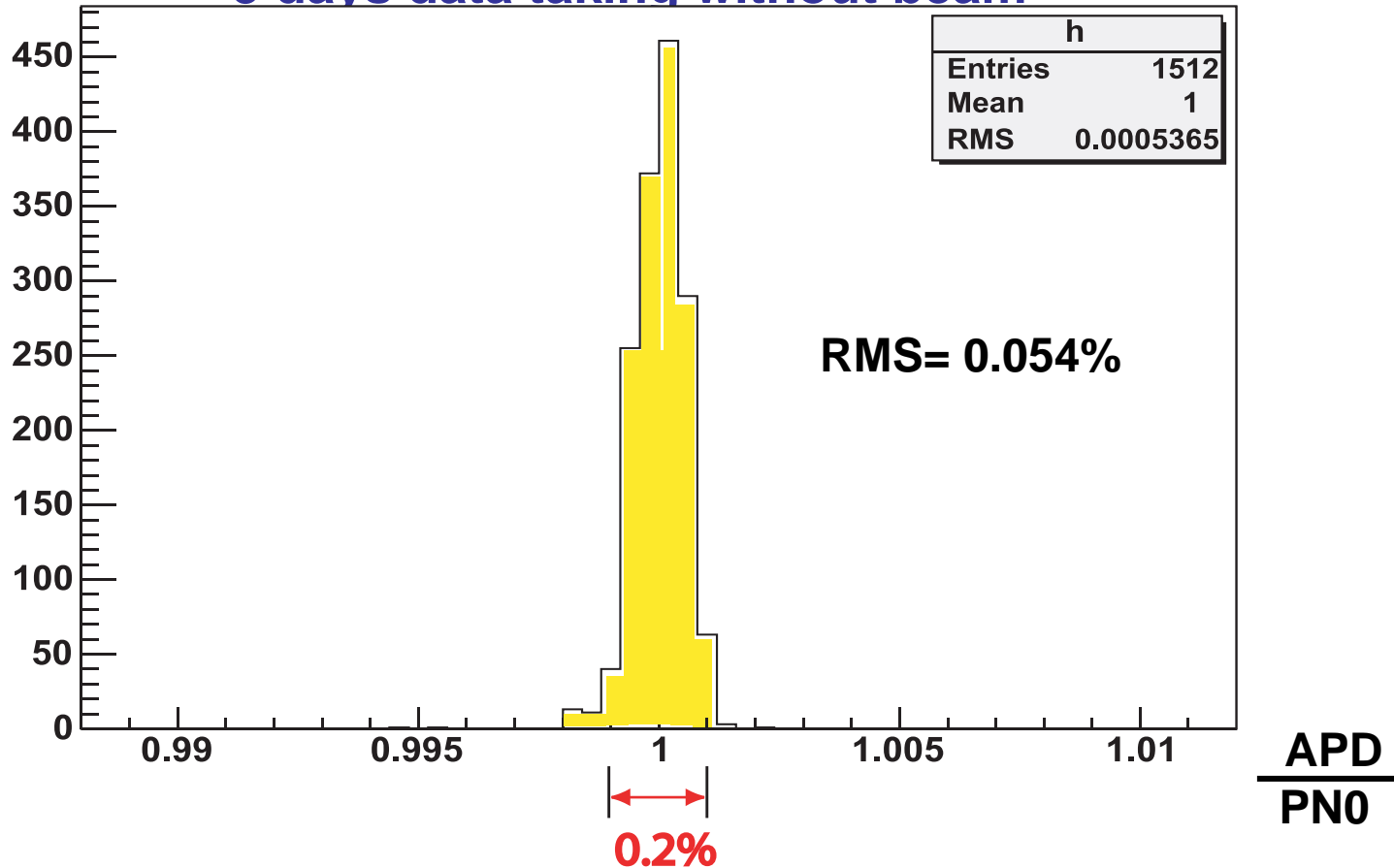

**Excellent Stability of the Monitoring System.
⇒ Allows Precise Monitoring of Radiation Damage.**



Laser Monitoring Application



Tracking damage and recovery with laser light

Channel 54 (XTal 1314)

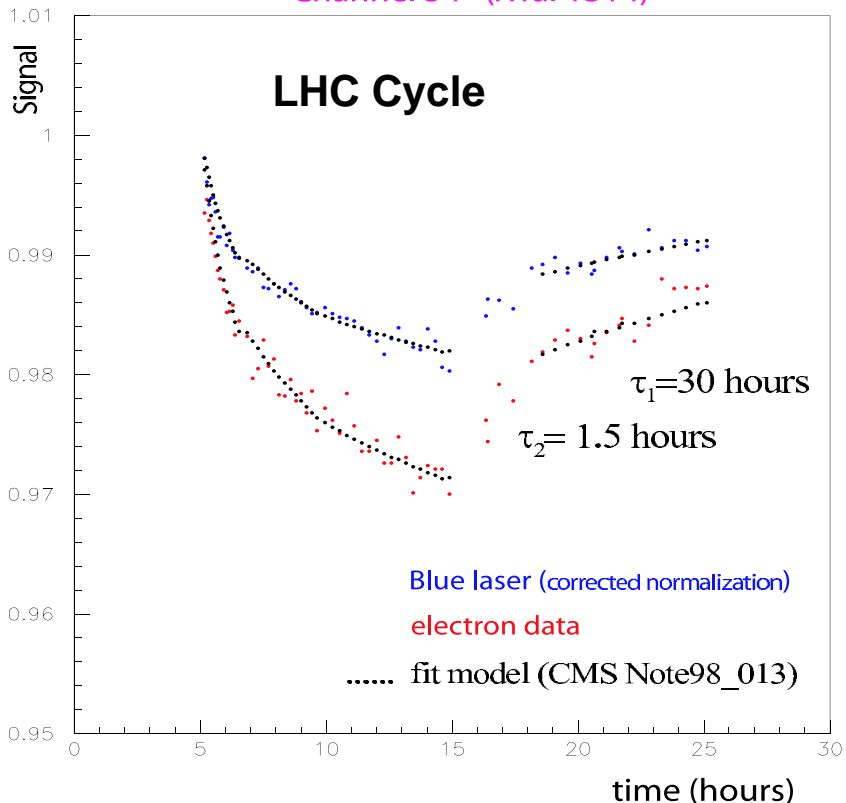

Correcting radiation damage

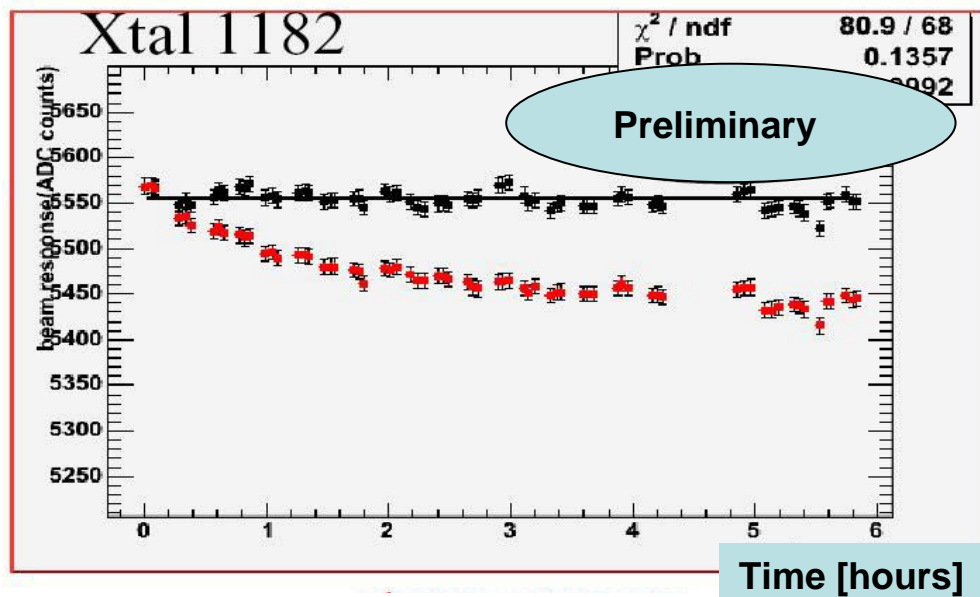



Beam Test Spring/Summer 2004



➤ Test endcap supercrystals (SC) for the first time in final design !

ECAL Endcap/Barrel differ : APD/VPT, Monitoring Fiber into front/back of the Crystal, Geometry, Crystal Type (China/Russia)

➤ Test crystals from new suppliers (SIC China, Apatity Russia, BTCP Russia)

Prepare competitive bid for encap and possibly barrel crystals.

		SC04			SC03				
BTCP		0.95	0.49	0.78	1.13	0.13	0.82	0.63	0.14
Apatity		1.48	2.13	2.53	0.53	0.55	0.58	0.62	0.62
SIC, Jun 04		1.83	1.68	0.92	1.25	0.99	1.04	0.9	1.16
SIC, Jan		2.57	2.86	2.75	0.69	0.62	0.9	0.84	0.74
		-----	-----	2.70	1.6	0.49	1.2	0.8	1.4

← 'Induced Absorption'
(a measure of the radiation hardness)

Variation of crystals properties does not necessarily impact monitoring performance.



Irradiation Studies 2004 - Apatity



Irradiation neighbor Crystal

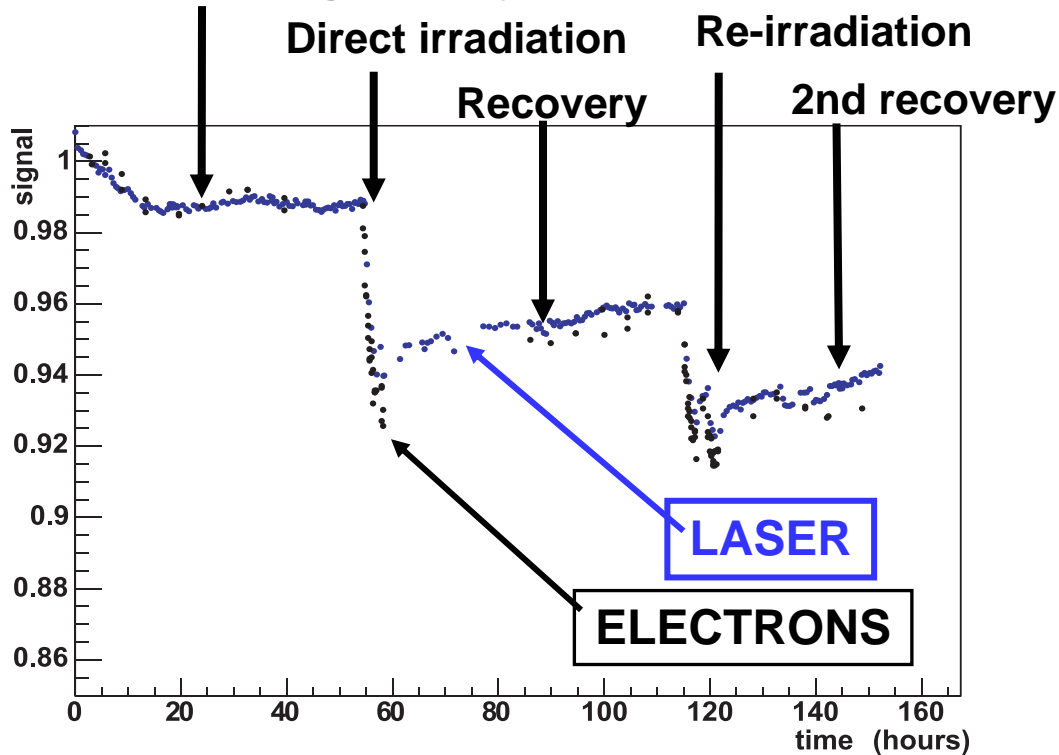

Total Dose : 4.6 G

Dose Rate : 4x Barrel Rate (60 rad/h)

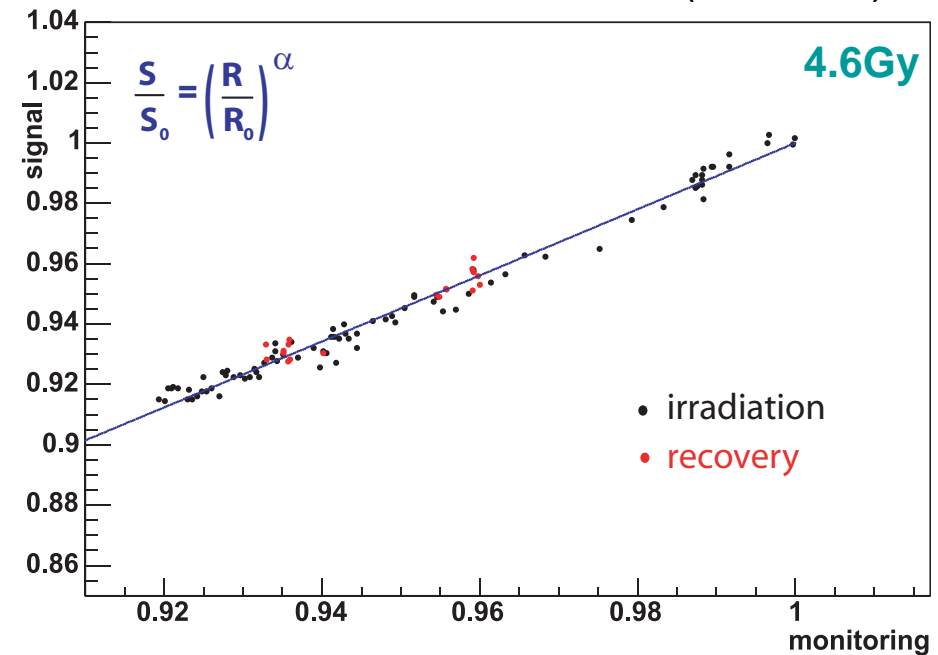

- Very precise measurement of radiation induced transparency loss.
⇒ Fast response for Crystal procurement !
- Systematic effects on final correction under investigation.



Irradiation Studies 2004 - SIC



Crystal not irradiated to saturation!

Direct irradiation

Re-irradiation

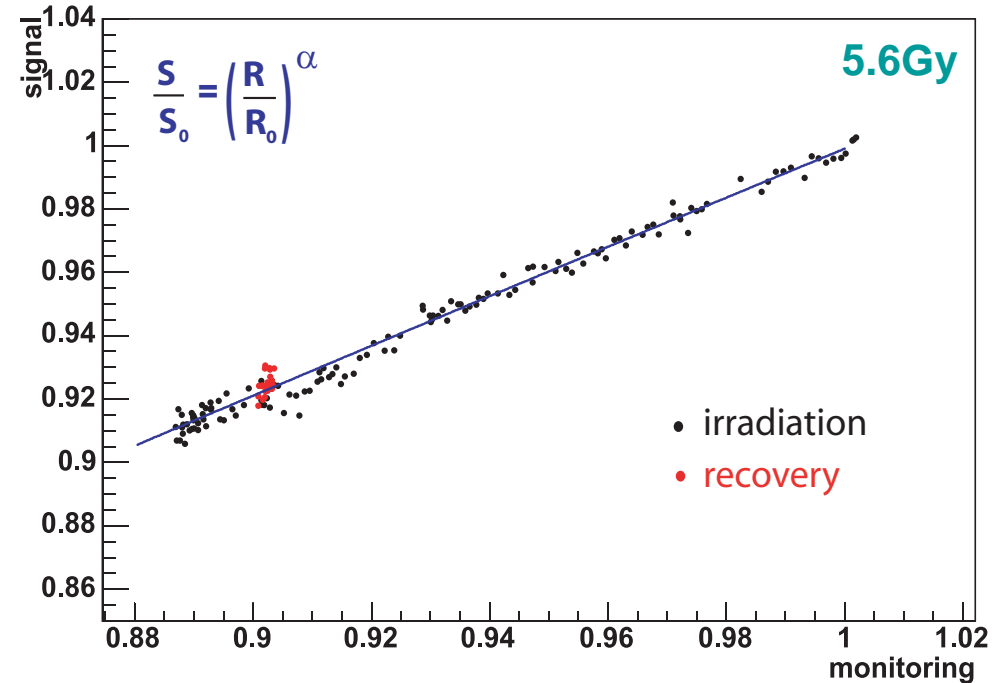
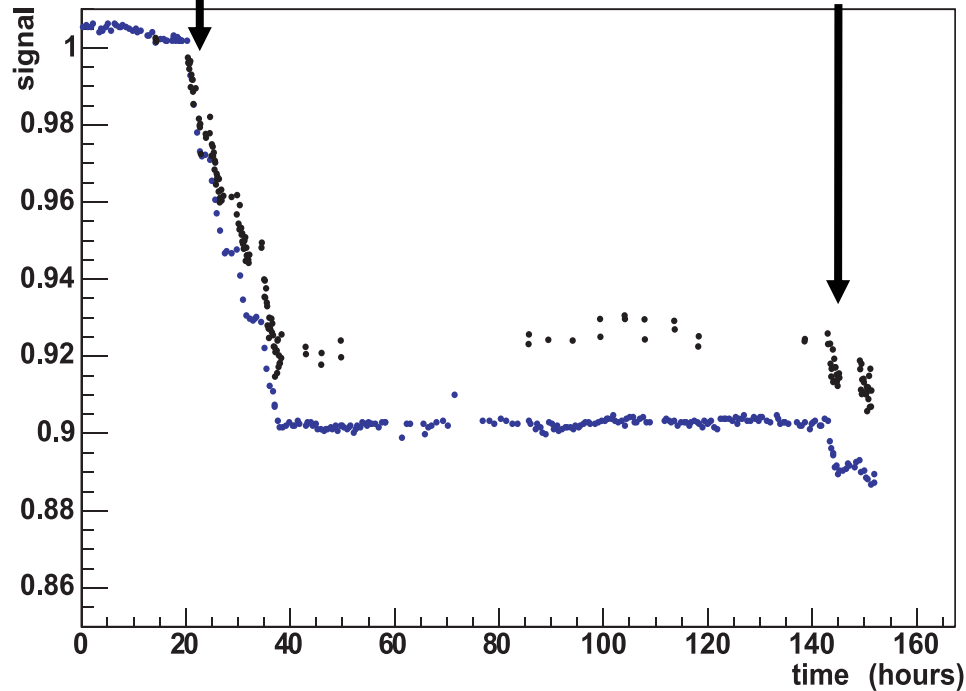

⇒ SIC Crystals recovery time constant is much longer than for Russian Crystals !



Summary



**Precise Monitoring and Calibration are essential to reach full ECAL performance !
A full performance ECAL is a key ingredient of CMS to reach full discovery potential !**

- **Completed two extensive beam test periods in 2003 (1200 h) and 2004 (+2500 h).**
- **Monitoring System performs very well and reliably.**
- **Many important ECAL issues have been proven to work in the beam test.
(Proof of principle)**
- **Detailed systematic studies how to reach ultimate performance are now underway.**
- **This will be a continuous process and will have to link to the in-situ calibration.**