

"A 3D Tracking Trigger at CDF" or "Dealing with high luminosity running at the Tevatron"

Brian L. Winer
Ohio State University
CDF Collaboration.

Project includes physicists
and Engineers from:
Ohio State, Baylor, Fermilab,
Illinois, Purdue

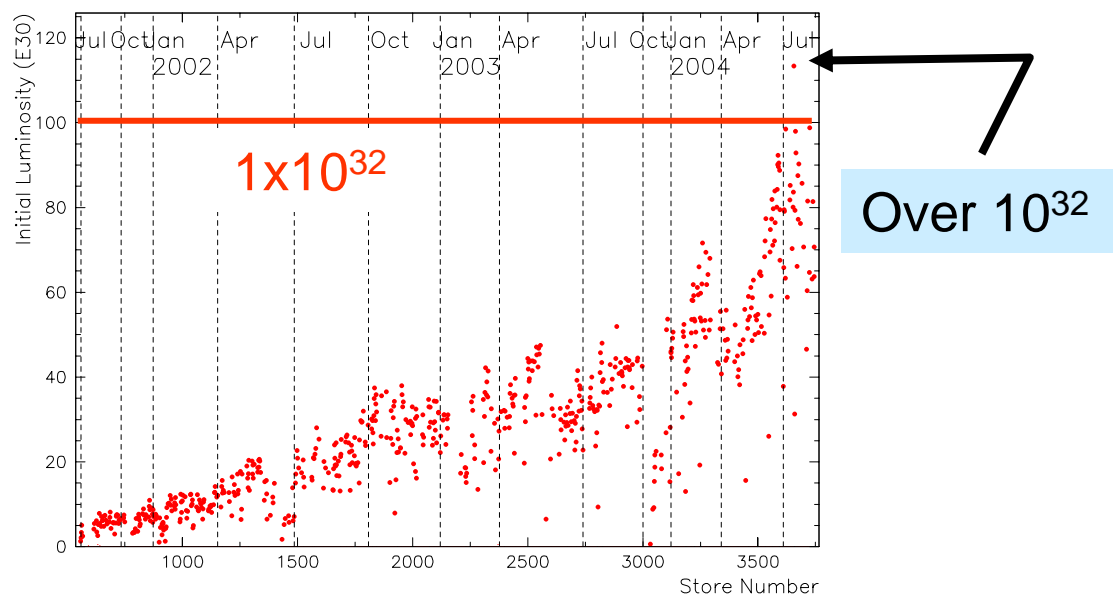

- Role of tracking
 - **Top, W/Z, Exotic Physics** triggers require **High momentum** electron and muon **Level 1 trigger** candidates
 - **Bottom Physics** require **low momentum** tracking at the **Level 1 trigger**
 - ❑ electrons
 - ❑ muons
 - ❑ hadronic tracks
- L1 Trigger Primitives
 - **Electrons:** XFT track + EM cluster
 - **Muons:** XFT track + muon stub
- L2 Trigger Tracks
 - XFT Track + Silicon Hits

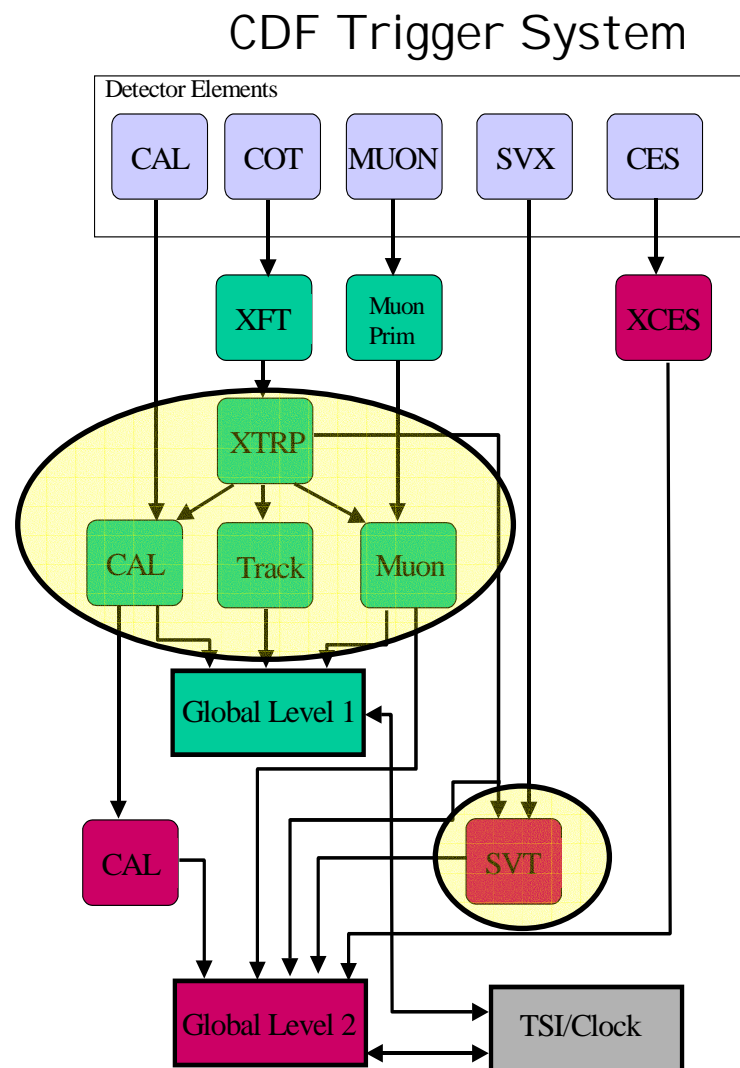

Overview of Existing XFT



- Hit Finding: Mezzanine Card
 - Hits are classified as prompt or delayed (i.e. "2-bin")
- Segment Finding
 - In the axial layers, search for patterns of prompt/delayed hits consistent with High Pt tracks
 - Each segment found is assigned a pixel (phi, all layers) and possibly a slope (outer 2 axial layers only)
- Track Finding
 - Looking across 3 or 4 axial layers, search for patterns of segments consistent with $P_t > 1.5$ GeV/c
 - Resultant Pt and Phi of all > 1.5 GeV/c tracks sent on to XTRP
 - Maximum of 288 tracks reported

Good hit patterns are identified as segment, then segments are linked as tracks

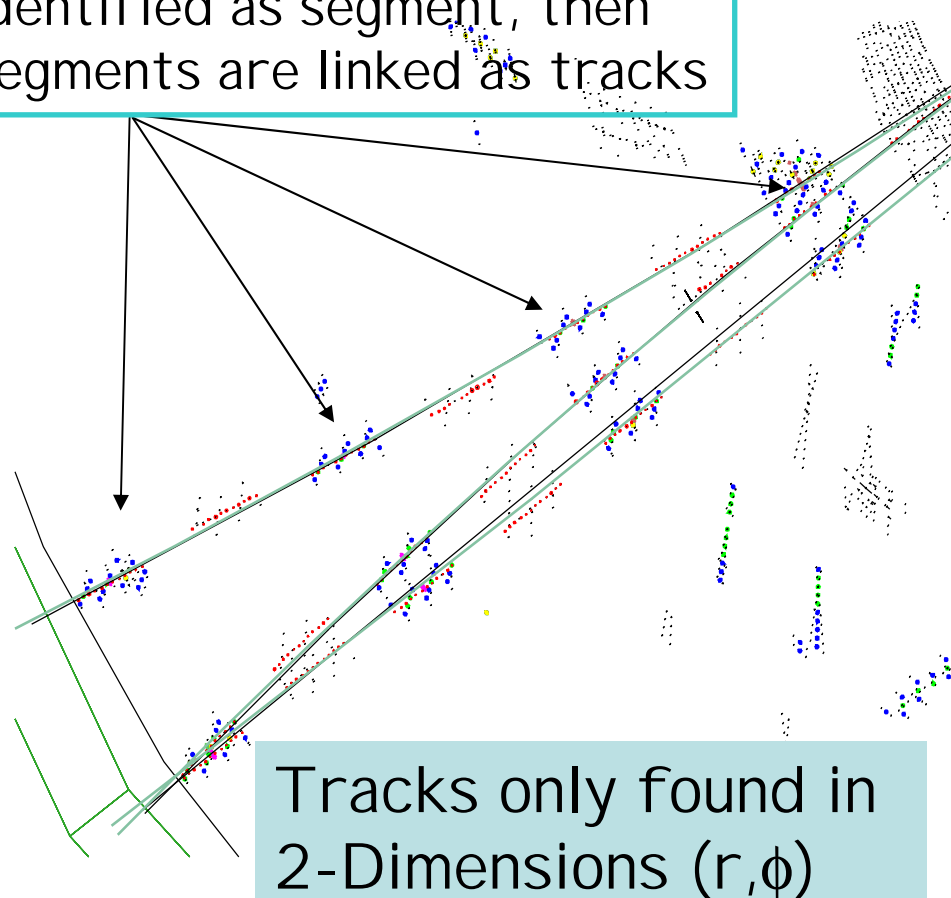

Tracks only found in 2-Dimensions (r, ϕ)

Why an Upgrade?



- The XFT was designed for a luminosity of:
 - $L=1 \times 10^{32} \text{cm}^{-2}\text{s}^{-1}$ with 396nsec bunch
 - $\langle \text{int/crossing} \rangle \sim 3$
 - $L=2 \times 10^{32} \text{cm}^{-2}\text{s}^{-1}$ 132nsec bunch
 - $\langle \text{int/crossing} \rangle \sim 2$
- Accelerator Performance
 - Max luminosity attained: $1 \times 10^{32} \text{cm}^{-2}\text{s}^{-1}$
 - Expect to reach $L=3 \times 10^{32} \text{cm}^{-2}\text{s}^{-1}$ at **396nsec bunch crossing**
 - $\langle \text{int/crossing} \rangle \sim 9$
 - Factor of 3-4 above design

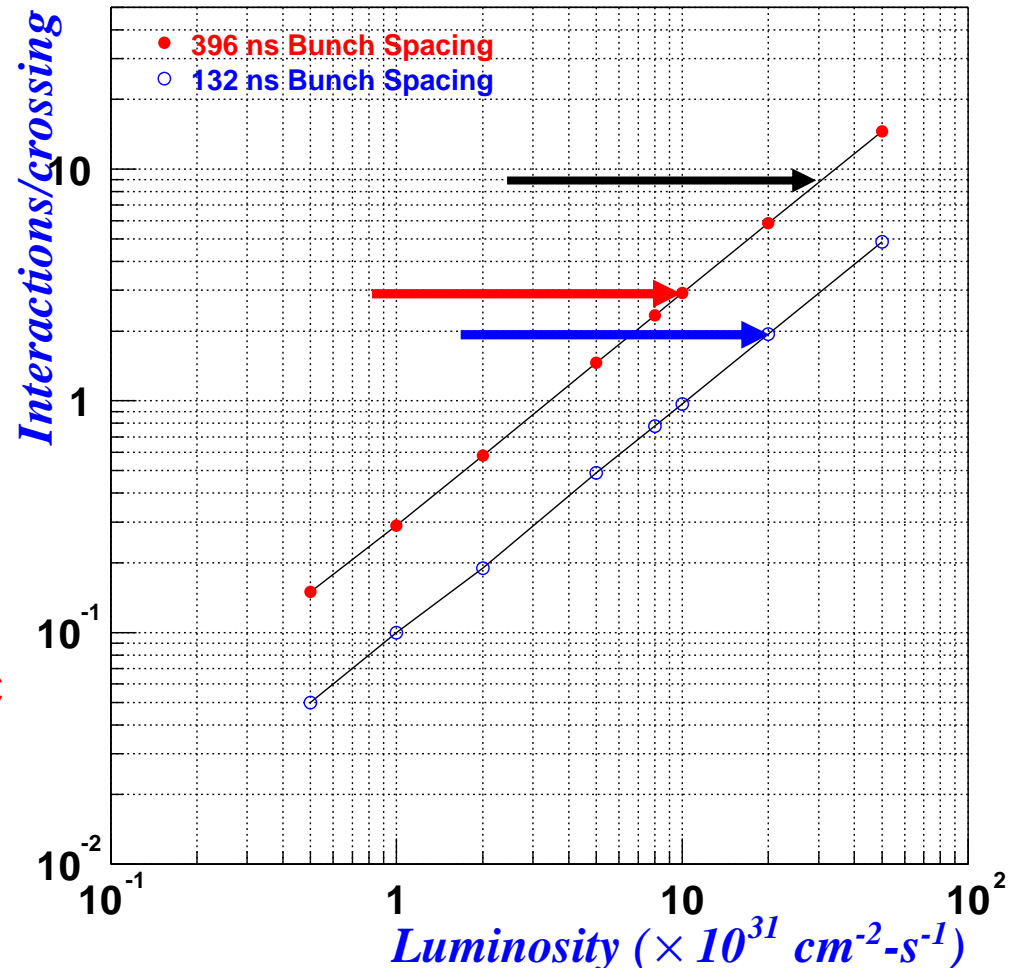



$Z \rightarrow ee$ at low lum.
0 add. Int./crossing

Miss
It

List of tracks

Id pt phi eta

Cdf Tracks: first 5

157	-45.4	-2.2	1.0
158	25.7	0.9	-0.3
147	1.2	0.3	0.2
148	-1.6	-0.1	0.1
149	1.2	1.6	-1.3

To select track type

SelectCdfTrack(Id)

Svt Tracks: first 5

0	-5.7	0.2
---	------	-----

To select track type

SelectSvtTrack(Id)

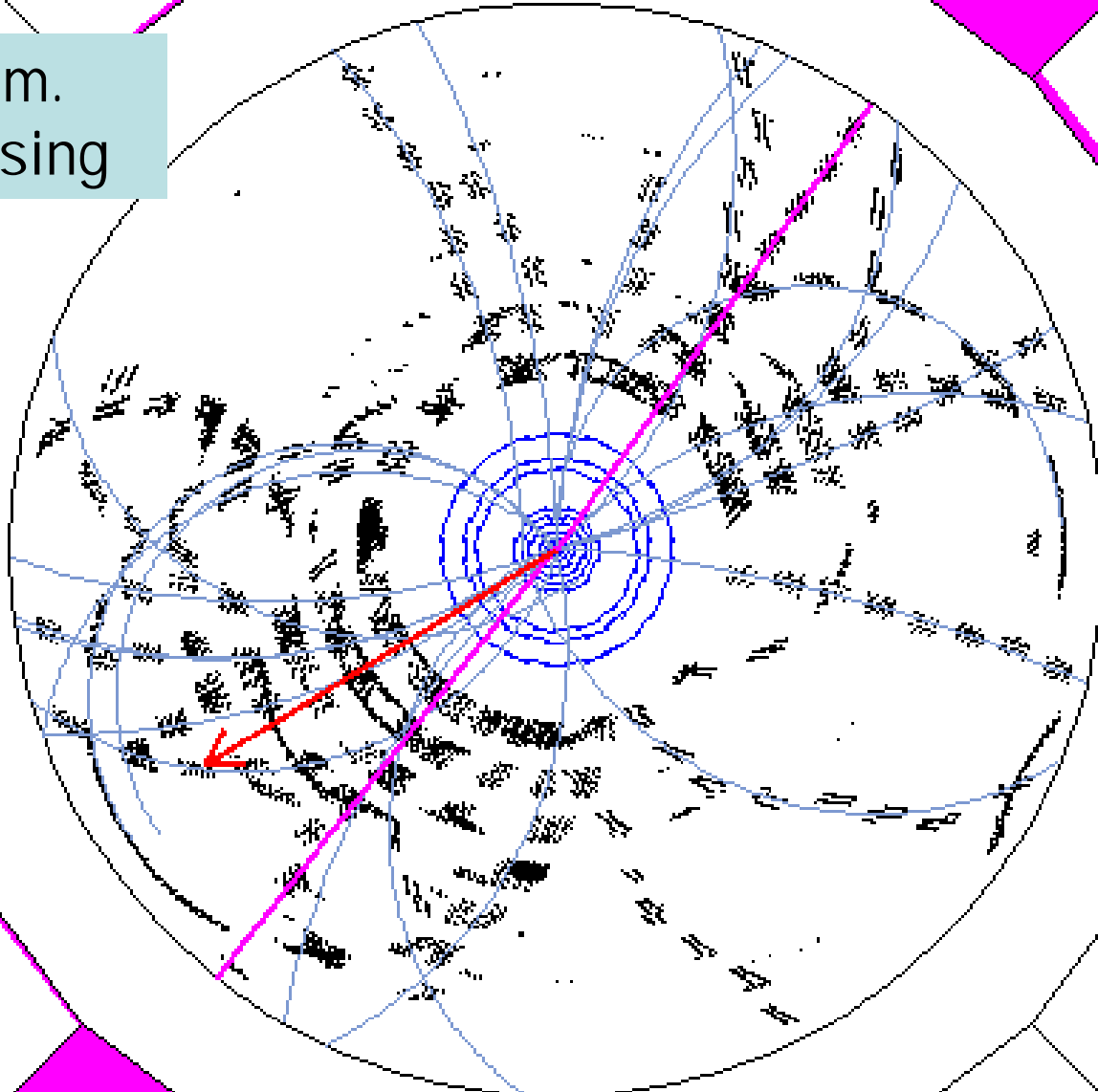



$Z \rightarrow ee$ at low lum.
2 add. Int./crossing

Miss
It

List of tracks

Id	pt	phi	eta
----	----	-----	-----

Cdf Tracks: first 5

157	-45.4	-2.2	1.0
158	25.7	0.9	-0.3
147	1.2	0.3	0.2
148	-1.6	-0.1	0.1
149	1.2	1.6	-1.3

To select track type

SelectCdfTrack(Id)

Svt Tracks: first 5

0	-5.7	0.2
---	------	-----

To select track type

SelectSvtTrack(Id)

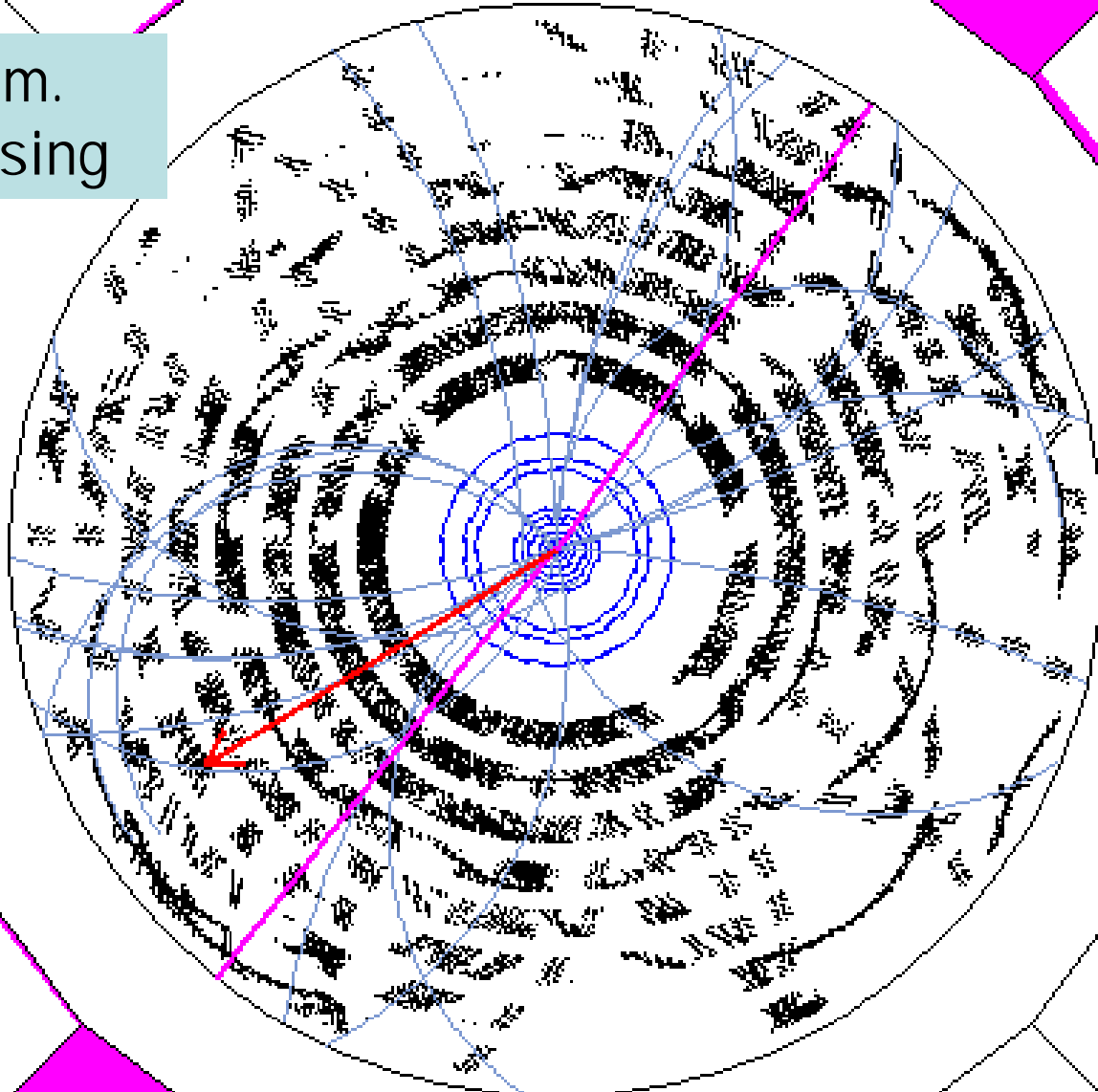



$Z \rightarrow ee$ at low lum.
5 add. Int./crossing

Miss
It

List of tracks

Id	pt	phi	eta
----	----	-----	-----

Cdf Tracks: first 5

157	-45.4	-2.2	1.0
158	25.7	0.9	-0.3
147	1.8	0.3	0.2
148	-1.6	-0.1	0.1
149	1.2	1.6	-1.3

To select track type

SelectCdfTrack(Id)

Svt Tracks: first 5

0	-5.7	0.2
---	------	-----

To select track type

SelectSvtTrack(Id)

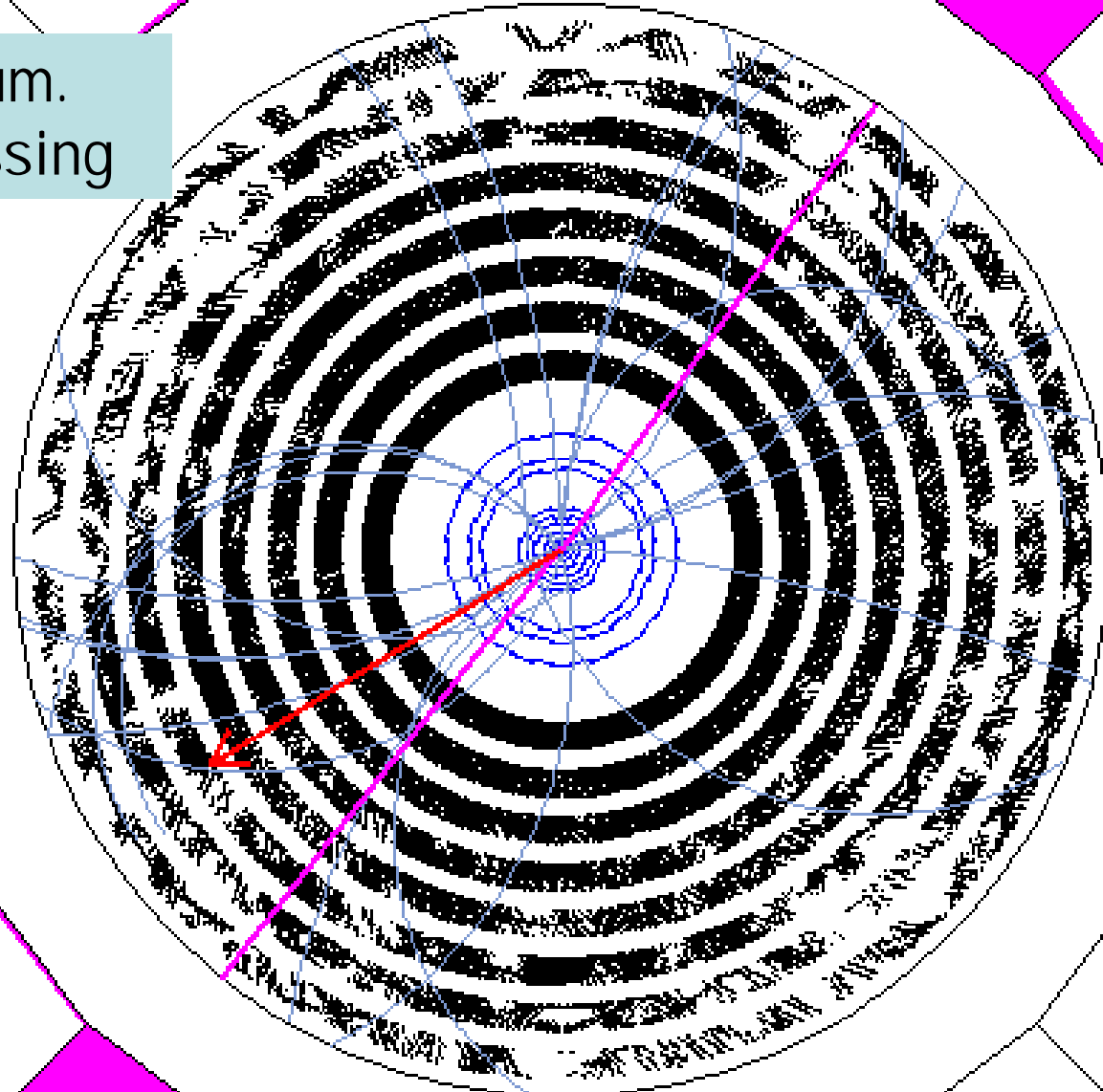



Z → ee at low lum.

10 add. Int./crossing

Miss
It

List of tracks

Id pt phi eta

Cdf Tracks: first 5

157	-45.4	-2.2	1.0
158	25.7	0.9	-0.3
147	1.8	0.3	0.2
148	-1.6	-0.1	0.1
149	1.2	1.6	-1.3

To select track type

SelectCdfTrack(Id)

Svt Tracks: first 5

0	-5.7	0.2
---	------	-----

To select track type

SelectSvtTrack(Id)

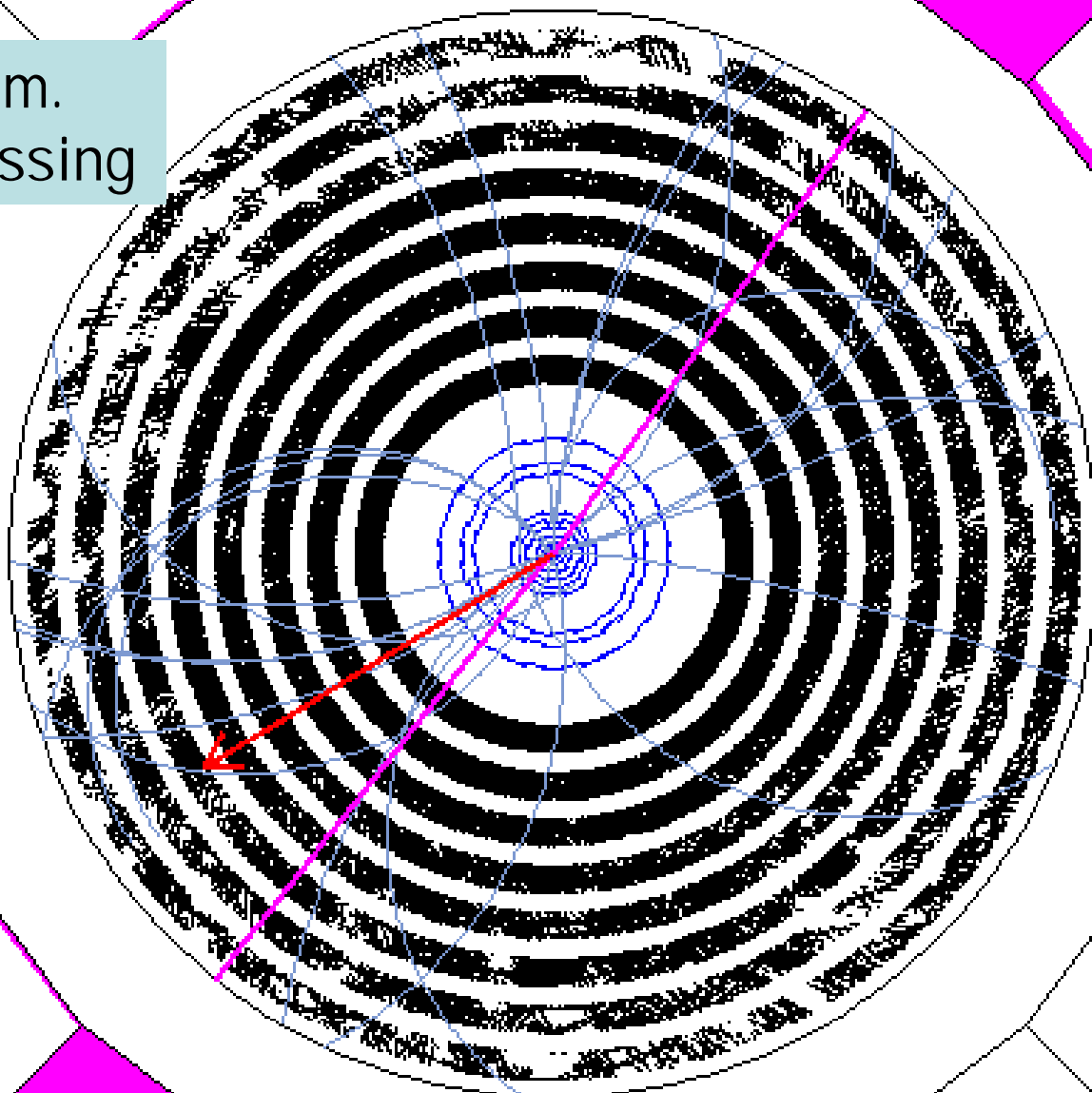



Z → ee at low lum.

10 add. Int./crossing

List of tracks

Id pt phi eta

Cdf Tracks: first 5

157	-45.4	-2.2	1.0
158	25.7	0.9	-0.3
147	1.8	0.3	0.2
148	-1.6	-0.1	0.1
149	1.2	1.6	-1.3

To select track type

SelectCdfTrack(Id)

Svt

0

To select track type

SelectSvtTrack(Id)

Resolution of COT much better than resolution of picture

Two-Track Triggers



- Two Track Trigger for B Physics

- 2 tracks $p_T > 2.5$ GeV
- Opposite charge
- $p_T(1) + p_T(2) > 6.5$ GeV
- $\delta\phi < 135^\circ$

- Quadratic growth (overlaps + **fakes**)

- $\sigma(L=5E31)/\sigma(L=0)=1.5$

- Extrapolate:

- linear $\sigma(L=1.5E32) = 225\mu\text{b} \Rightarrow 34\text{kHz}$
- Real (from overlapped MB) $\sigma(L=1.5E32) = 500\mu\text{b} \Rightarrow 75\text{kHz}$

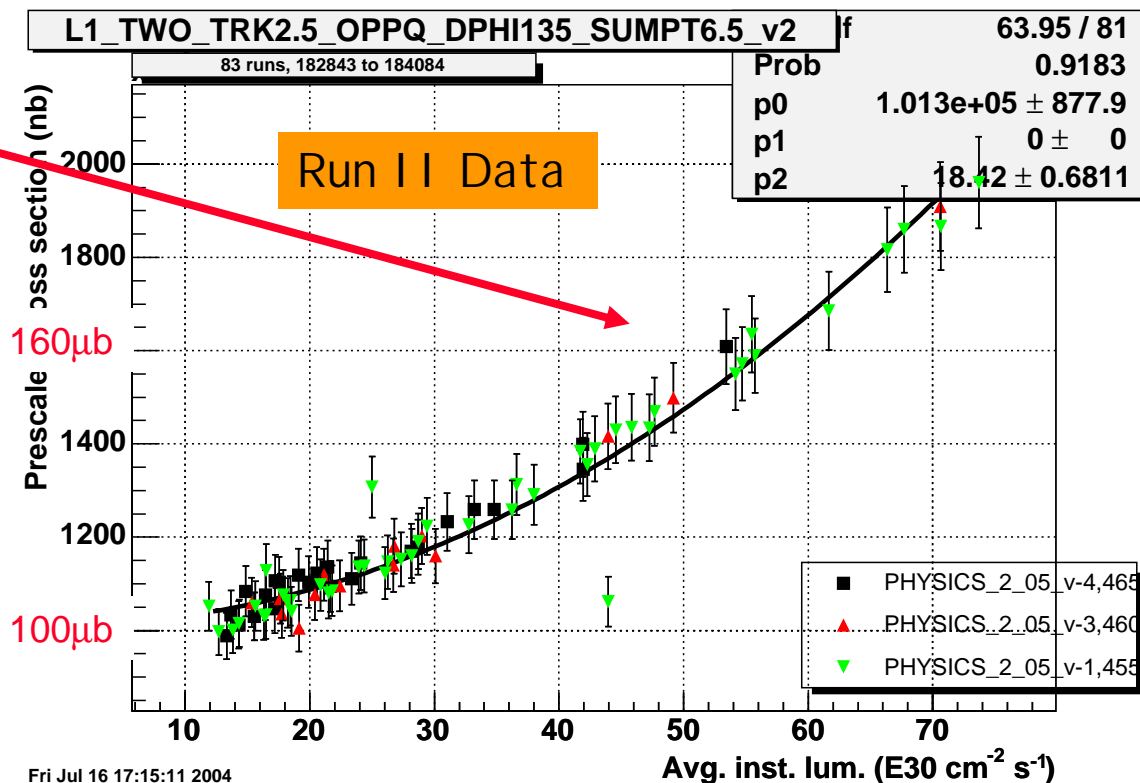

Expected Bandwidth (Accept Rate):

L1: 30 kHz L2: 1 kHz L3: 100 Hz

What's needed:



- Primary problem is the growth of fake tracks due to pattern recognition problems:

Fake tracks can be made from pieces of different real physical tracks.

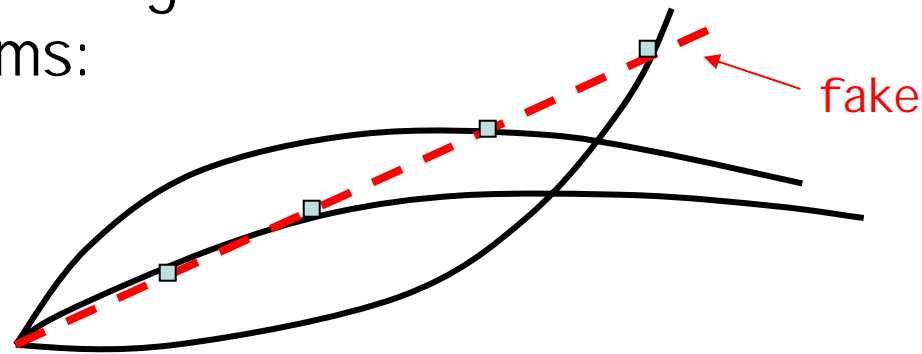

- Need a way to model the highest luminosity running
 - Simulations of the XFT System
 - Study the effect of high luminosity running on a variety of triggers
 - ❑ Two-Track Trigger (low P_T)
 - ❑ Single Track Trigger (high P_T : Track Only)
 - ❑ Electron Trigger (Track + Other object)
- Trigger Rate is the "Figure of Merit"
- Consider modifications/additions to the current system
 - Reduce fake rate
 - Maintain resolution

- All events are passed through a hit-level simulation
 - Start with COT hits
 - Gives *exactly* the same answer as hardware when run with same masks, roads and XFT hits
 - Outputs XFT hits, pixels, and tracks for axial and XFT pixels for stereo
- Simulate High luminosity by Merging events “main” event with zero bias
 - Merge COT hits (combine overlapping hits)
 - Add tracks from individual events together
 - ❑ Offline tracks serve as “truth” for the event
 - This method allows us to probe up to 4E32

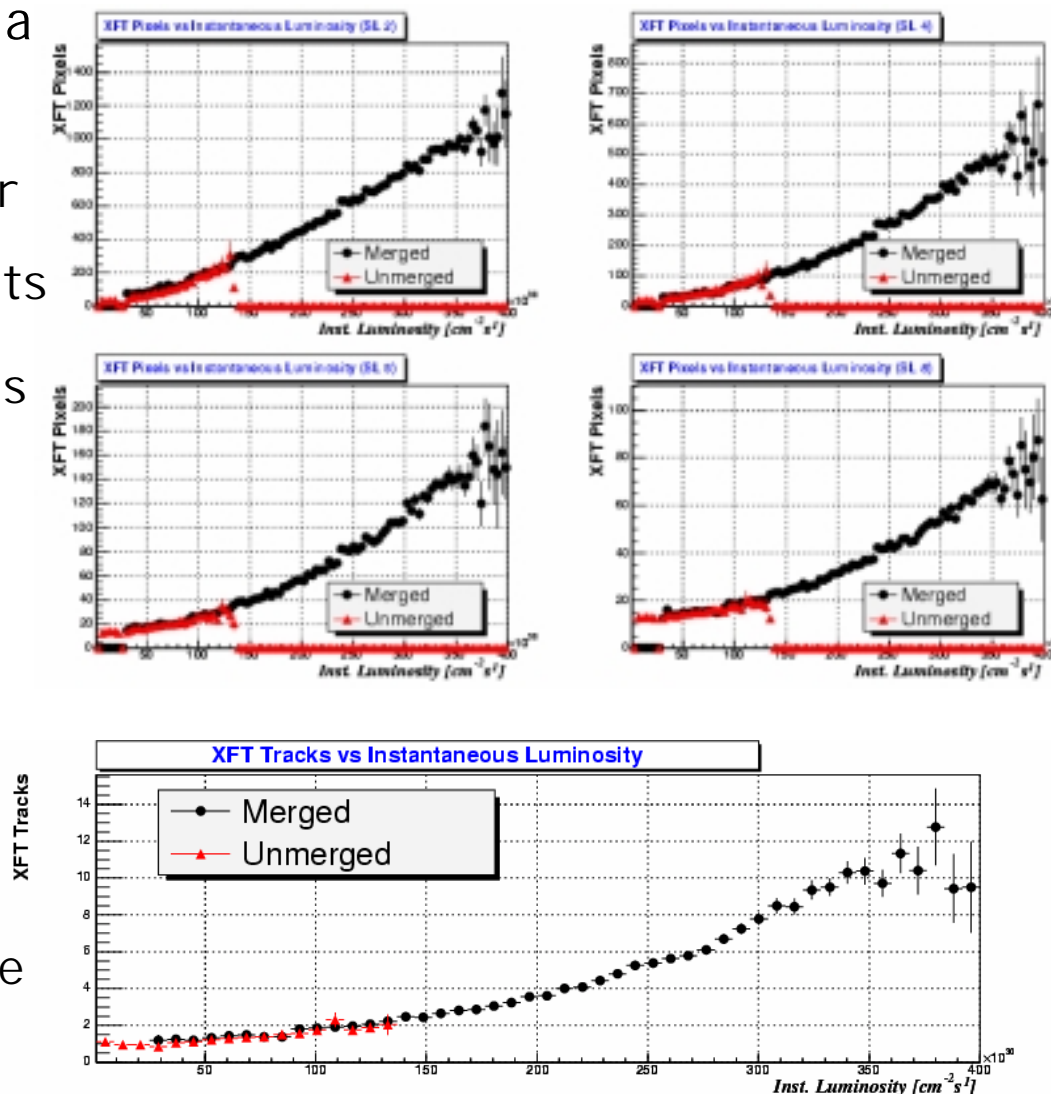

- Studied various upgrade paths
 - Replacing Axial System (Use additional 264ns between crossings)
 - Add information from Stereo Layers of COT
 - Doing both of above
- Advantages of Stereo Upgrade
 - Gives us the fake track rejection that we need.
 - Allows for more additional handles in trigger
 - ❑ Track pointing to other trigger primitives (L2)
 - ❑ Possibility of Two-Track Invariant Mass Cuts (Understudy)
 - Parallel Path to Axial System
 - ❑ Commission parasitically.
- Only Minor changes to Axial System
 - ❑ Slight Changes to existing firmware.
 - ❑ KEEP A WORKING SYSTEM
 - ❖ No extended downtime

We picked this.

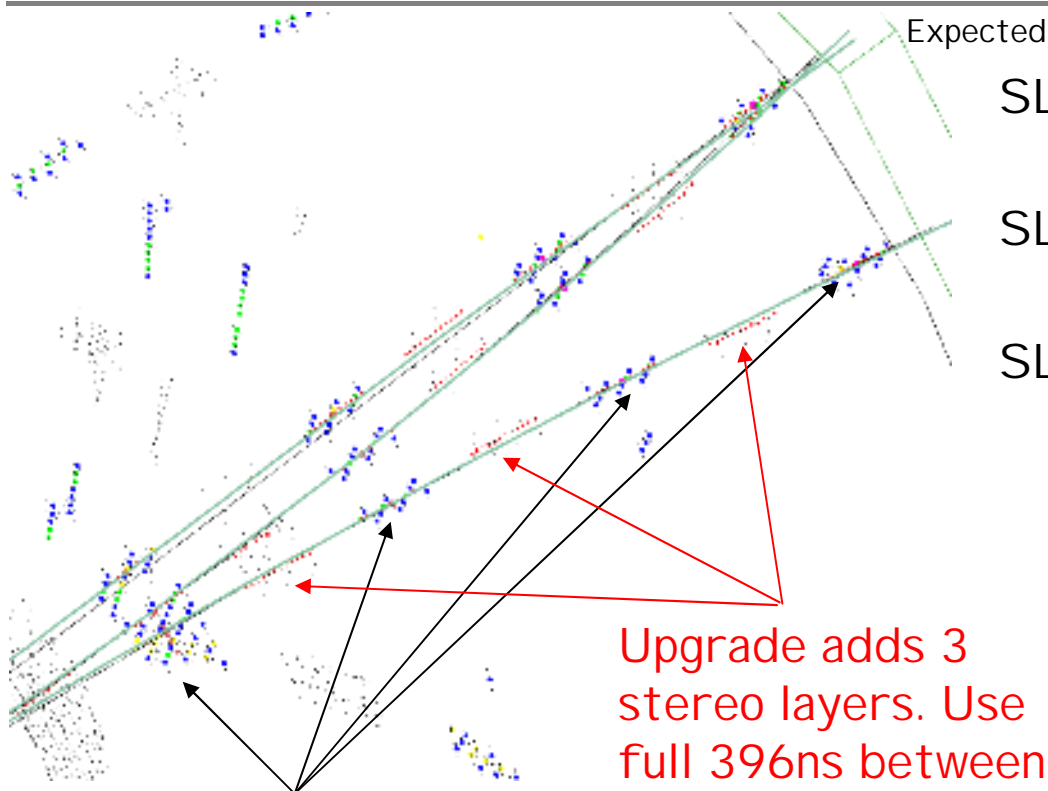

Current XFT uses 4 axial layers only

Upgrade adds 3 stereo layers. Use full 396ns between crossings to send more precise hit information.

Stereo algorithm exploits correlation expected for real tracks

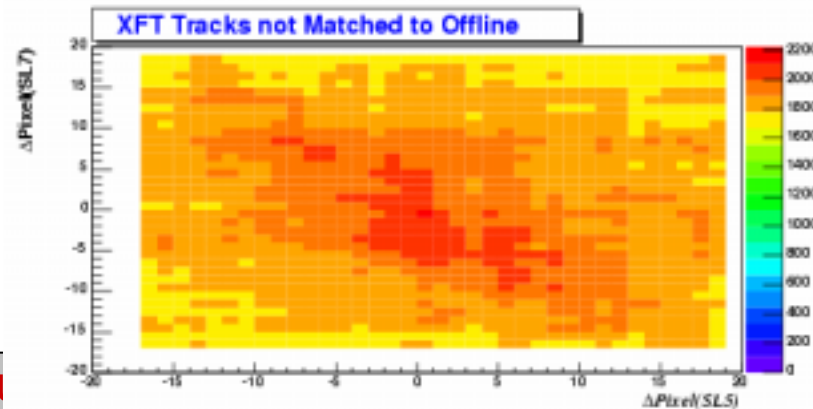
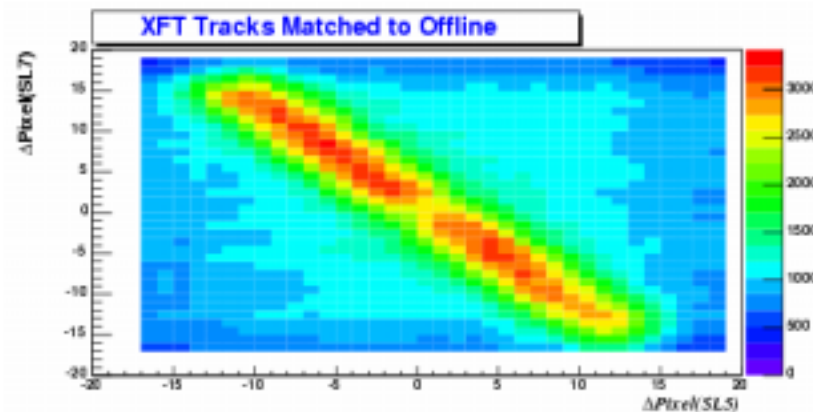
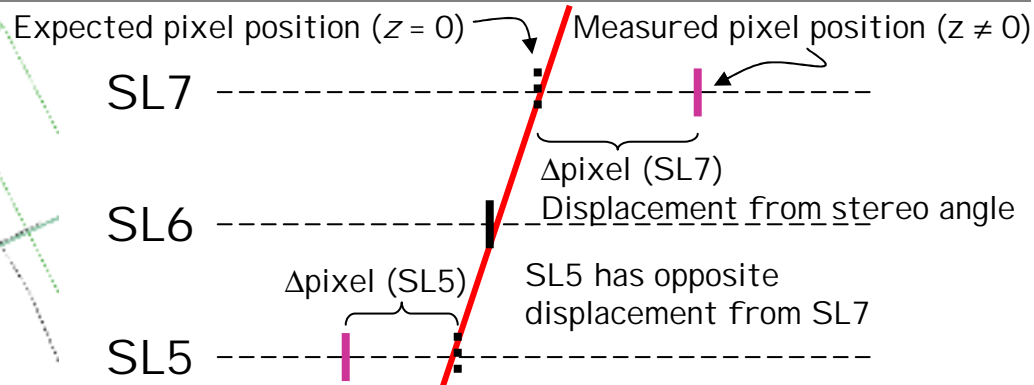

Current XFT Configuration

Ansley trigger cable (220 ft)
Data @45MHz LVDS

~2 m copper Cable Data
@33MHz (channel link)

Neighboring cards
connected over backplane

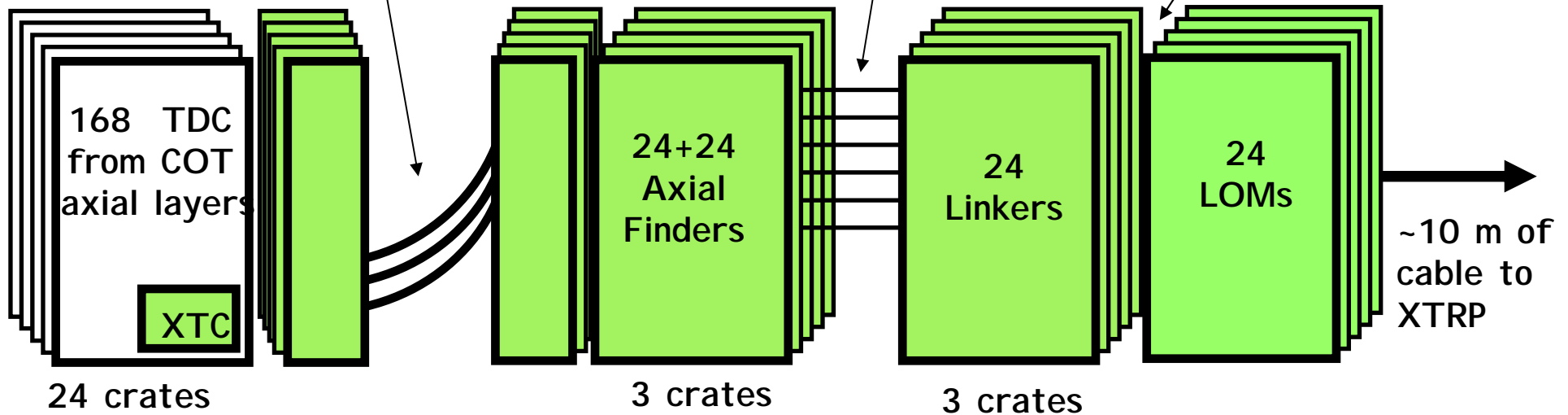

XFT Upgrade Configuration

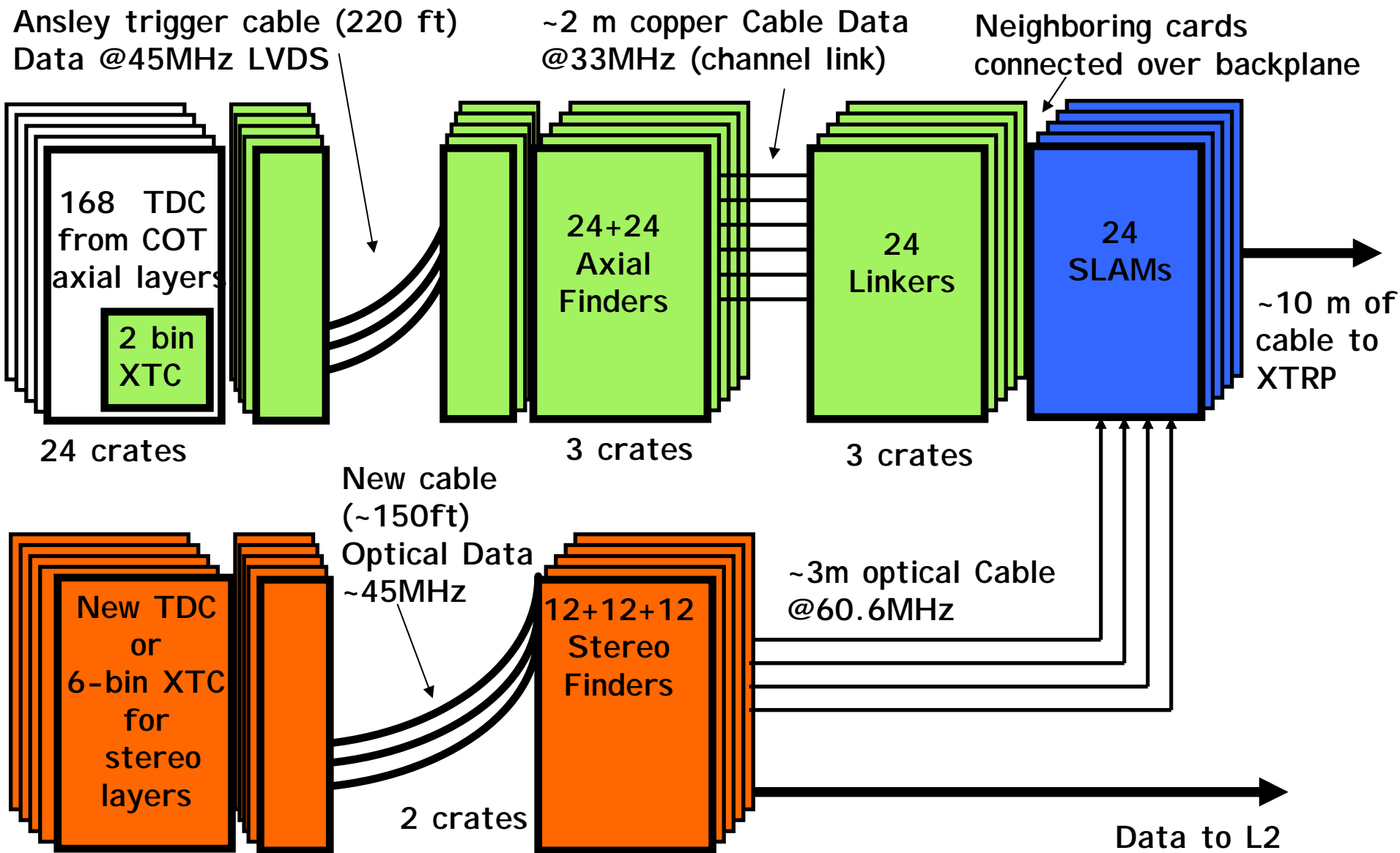

- Scenario C Two-Track Trigger

Lumi [1E32 cm ⁻² s ⁻¹]	0.5	1.0	1.5	2.0	3.0
2-Bin σ [mb]	0.12	0.28	0.50	0.78	1.5
Stereo σ [mb]	0.08	0.13	0.21	0.33	0.65
Ratio	0.37	0.38	0.39	0.40	0.42

Uses only 2 of 3 Stereo Layers

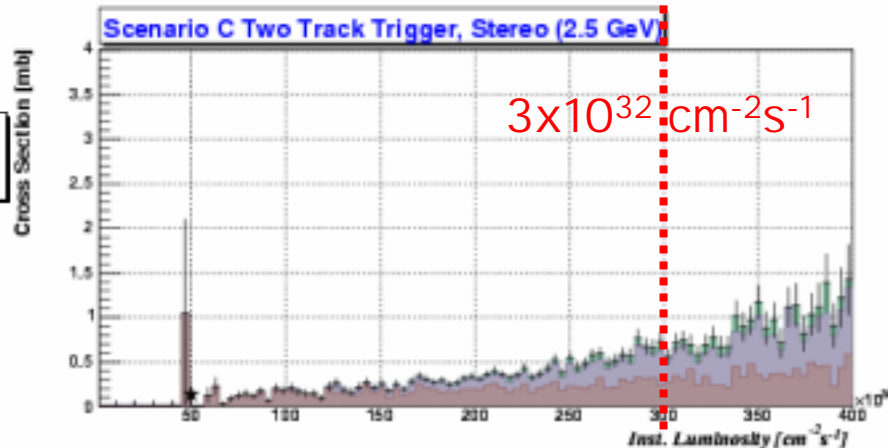
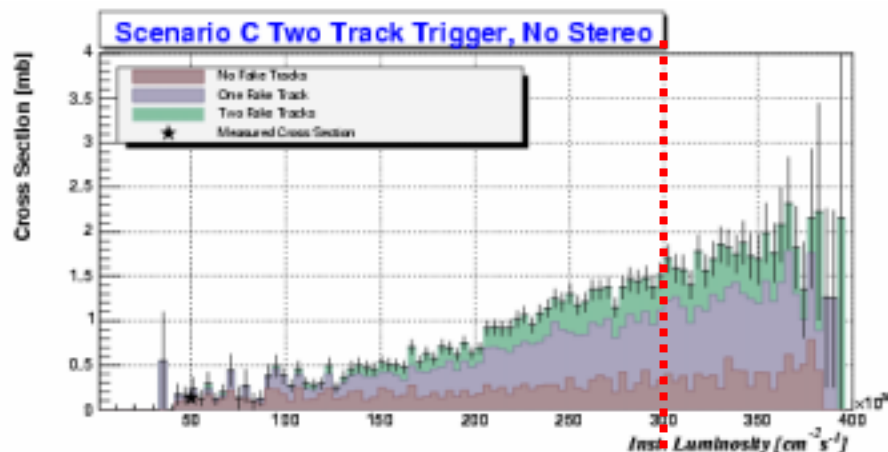
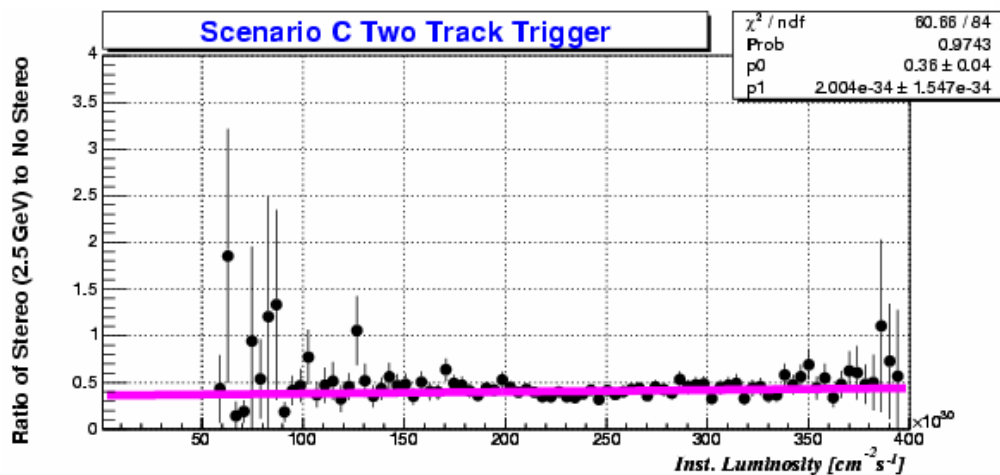

Luminosity →

- Accelerator performance has been excellent
 - But...high luminosity at 396nsec bunch spacing leads to many interactions/crossing
 - We need to upgrade the XFT to take advantage of the great opportunity
- The XFT Upgrade **will meet the needs** of high L running
 - This upgrade gives us the required factor of 3 rejection of fakes
 - System can be installed and commissioned with little impact on the current XFT
 - Not all capabilities have been explored
 - ❑ Current rejection only making use of 2 of 3 stereo layers.
 - ❑ Expect another factor of ~2 by using stereo extrapolation in Level 2
 - ❑ Mass triggers are also possible at Level 1 and/or Level 2
- Schedule:
 - Prototypes under design.
 - ❑ Make extensive use of experience from existing system.
 - Expect completed system in ~15 months
 - System Operational by Jan 2006.